

0–18 MHz Receiver

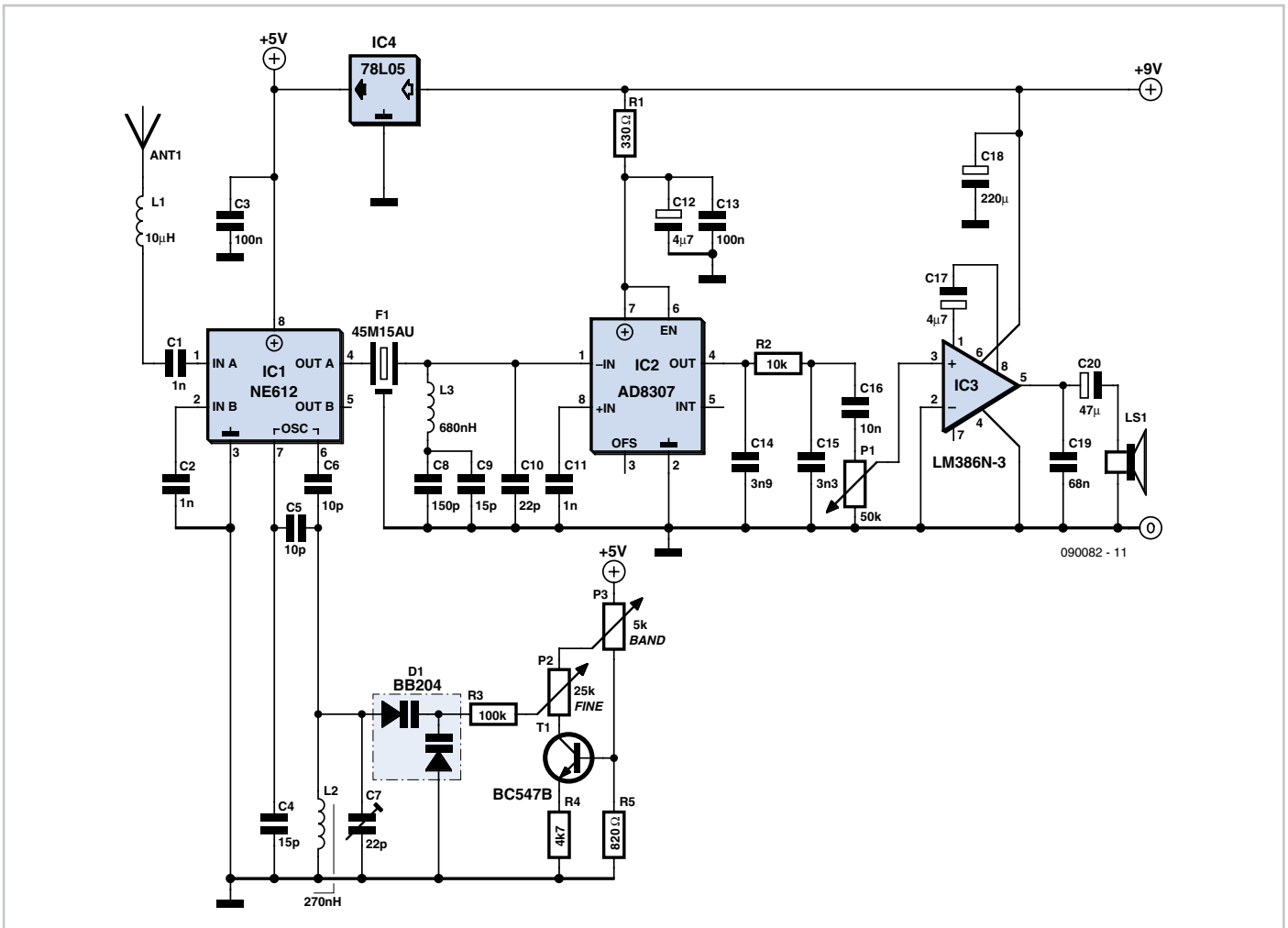

Gert Baars (The Netherlands)

The receiver shown in the schematic has some characteristics not unlike those of the so-called 'world band receivers' from the old days, which could usually receive LW, MW and SW up to about 20 MHz in AM and which were crammed with transistors. Because of the 'low-budget' character of this circuit it forgoes a tuning scale/indicator and the design has been kept as simple as possible. Nevertheless, the name 'Mini World Receiver' would not be inappropriate for this design. In the RF bands up to 30 MHz, the majority of stations can actually be found below 18 MHz. It is possible to make a receiver for this with a relatively simple circuit. The simplicity of the circuit is therefore its primary strength, but that does not mean that the results are poor. The receiver is a single superheterodyne with the salient characteristic that the receiving range from DC to 18 MHz can be tuned in a single range.

The circuit uses a high intermediate frequency (IF). This makes the image frequency

large, so that its suppression is very easy, which contributes to the simplicity of the circuit. This also means that the ratio between the highest and lowest required VFO frequencies remains small as well.

The circuit starts with a NE612 mixer IC (IC1), which also contains an oscillator. The oscillator is a Colpitts type and is tuned here using a dual-varicap diode (D1). The Mixer is followed by a crystal filter which has a centre frequency of 45 MHz and a bandwidth of 15 kHz. This bandwidth is a little large for AM, but the advantage of the filter, type 45M15AU, that is used here, is that it is priced quite favourably.

With an IF of 45 MHz and a receiving range from DC to 18 MHz, the VCO frequency therefore has to be $IF + F_0 = 45$ to 63 MHz. The image frequency is now 90 MHz higher than the desired receiver frequency, at 90–108 MHz. A single coil in series with the antenna provides sufficient suppression at these frequencies. It really cannot be any simpler.

After the IF filter follows an LC combination which suppresses the fundamental frequency of the IF filter (45M15AU is a 3rd overtone type) and increases the damping. A logarithmic detector was chosen for the IF amplifier. The advantage is mainly the small number of external components that are required for this. The detector is an AD8307 (IC2) and has a sensitivity of about -75 dBm, which works out to about 40 μ V. Together with the gain of the mixer (around 17 dB) the sensitivity of the receiver ends up at about 5 μ V. Because of the logarithmic characters of the detector, an AGC (automatic gain control) is not necessary. A simple RC filter subsequently provides some additional fundamental frequency and noise suppression.

The AF amplifier follows this filter and is configured for a gain of approximately 200. This is enough to drive a speaker so that it exceeds the ambient noise. If necessary the volume can be adjusted with P1. To tune such a large frequency range it is certainly preferable to use a multiturn

potentiometer. Because of the low-budget character of this design, a circuit around two potentiometers is used instead. A transistor configured as a current source provides a constant voltage of about 1 volt across the 'Fine' tuning potentiometer (P2). The 'Band' potentiometer (P3) has a negligible effect on the voltage across the 'Fine' potentiometer, but it does allow the voltage at both extremes to be changed. In this way the 'Band' control can be used to select a window within which the 'Fine' potentiometer is used for the actual tuning. The ratio is about 1 to 5. If you prefer a ratio of, say, 1 to 10, you can increase the emitter resistor R4 from 4.7 kohms to 10 kohms.

Because the VFO has to be stable, only the

power supply to the mixer/VFO IC has been regulated. The power supply voltage to the AD8307 has been reduced with a resistor to a safe value, while the AF amplifier is powered directly from the battery. The current consumption of the circuit without a signal is less than 20 mA and with good audible audio about 50 mA. The circuit continues to work well with power supply voltages down to about 6.5 volts. This means that a 9 V battery will last extra long.

Calibration of the circuit is simple. The tuning potentiometers have to be set to the lowest frequency first. Use trimmer capacitor C7 to find a point where AC power line hum becomes audible. Here the receiver fre-

quency is at 0 Hz. Optionally you can also tune to a strong longwave station as the lowest receiver frequency.

As a minimum a simple telescoping antenna with a length of 50 cm is required, which makes the receiver eminently suitable for portable use. With such an antenna dozens of stations are audible, particularly during the evening when propagation becomes favourable. A length of wire several meters long does however increase the signal strength, particularly during the day, but it is not strictly necessary.