

EVAL-MELODY-7 Audio/Video Evaluation Board

Change Log

| Revision | Date | Description |
|----------|------------|-----------------|
| 0.1 | 2016/08/30 | Initial Release |
| | | |
| | | |
| | | |
| | | |

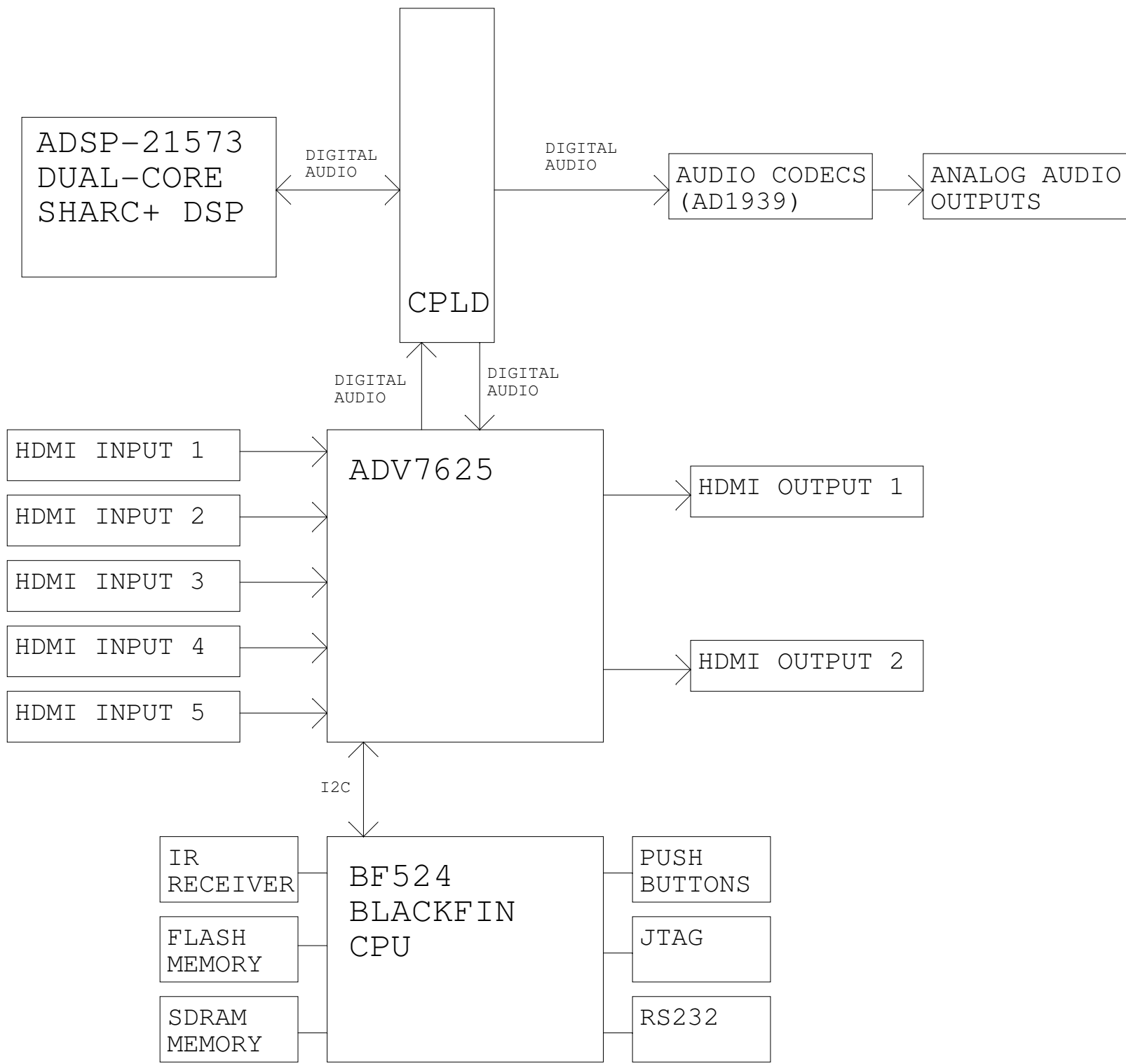

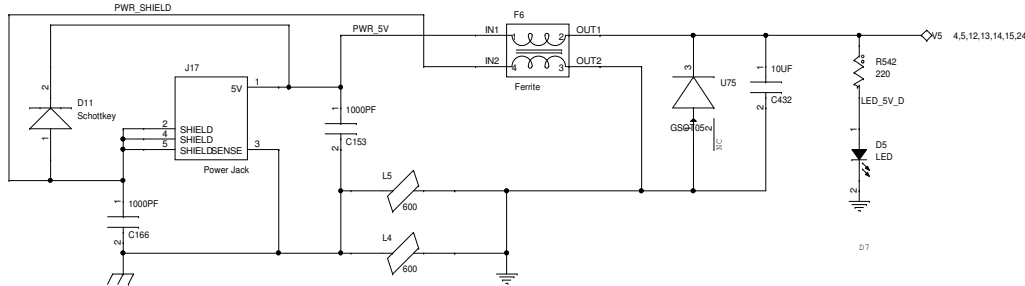
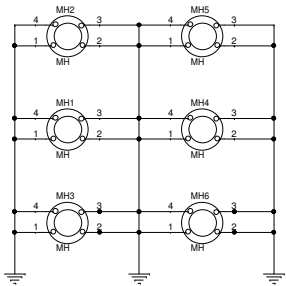

3,4,5,6,7,8,9,10,11,14,15,16,17,18,20,21,22,23,24,25,26,27,28,29,30,31,32,33,34,35,36,37,38,39

3,4,5,6,7,8,9,10,11,14,15,16,17,18,20,21,22,23,24,25,26,27,28,29,30,31,32,33,34,35,36,37,38,39

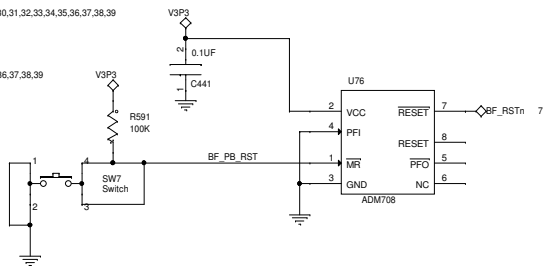

3,4,5,6,7,8,9,10,11,14,15,16,17,18,20,21,22,23,24,25,26,27,28,29,30,31,32,33,34,35,36,37,38,39

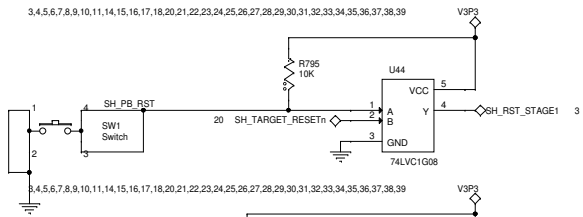

3,4,5,6,7,8,9,10,11,14,15,16,17,18,20,21,22,23,24,25,26,27,28,29,30,31,32,33,34,35,36,37,38,39

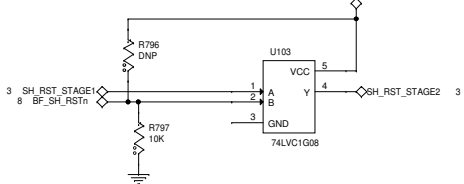

3,4,5,6,7,8,9,10,11,14,15,16,17,18,20,21,22,23,24,25,26,27,28,29,30,31,32,33,34,35,36,37,38,39

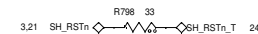
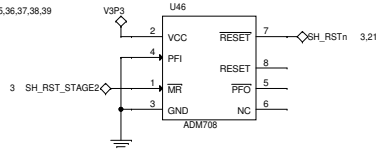

| | | |
|-------------|--|---------------|
| Title | | |
| BOARD POWER | | |
| Size | Document Number | Rev |
| C | EVAL-MELODY-7 Audio/Video Evaluation Board | 0.2 |
| Date: | Wednesday, January 04, 2017 | Sheet 3 of 40 |

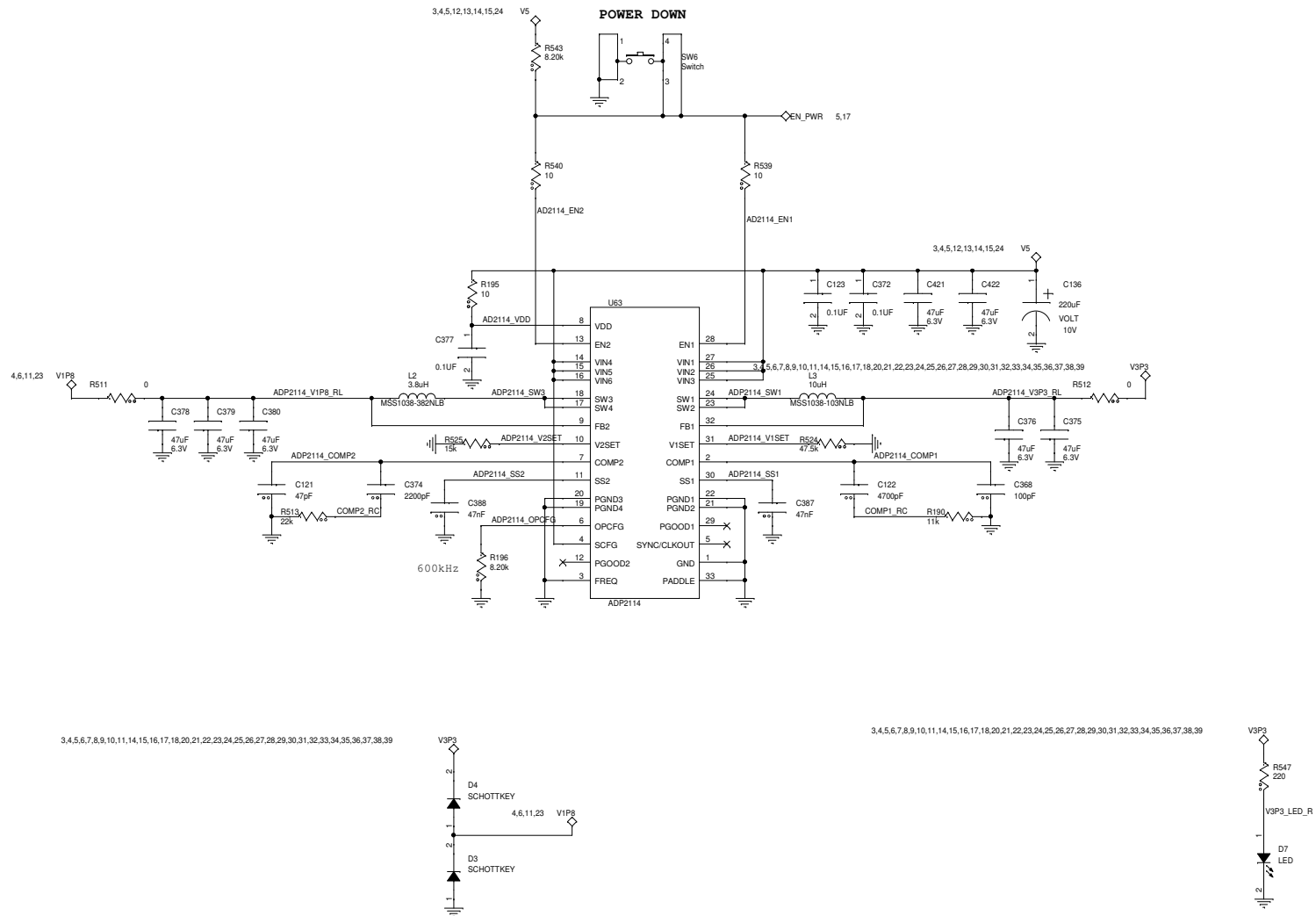

3,4,5,6,7,8,9,10,11,14,15,16,17,18,20,21,22,23,24,25,26,27,28,29,30,31,32,33,34,35,36,37,38,39

3,4,5,6,7,8,9,10,11,14,15,16,17,18,20,21,22,23,24,25,26,27,28,29,30,31,32,33,34,35,36,37,38,39

| | | |
|---------------------------------------|--|---------------|
| Title | | |
| SWITCHING REGULATOR FOR 3.3V AND 1.8V | | |
| Size | Document Number | Rev |
| C | EVAL-MELODY-7 Audio/Video Evaluation Board | 0.2 |
| Date: | Wednesday, January 04, 2017 | Sheet 4 of 40 |

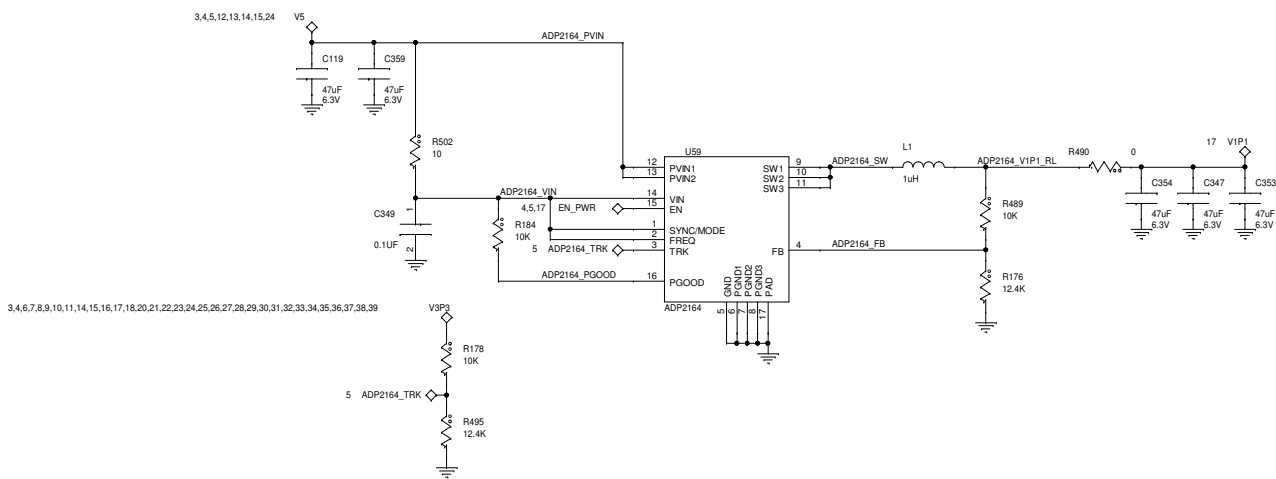
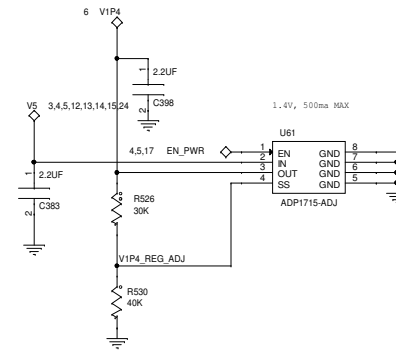
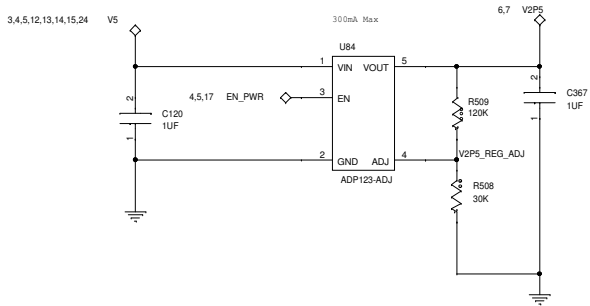

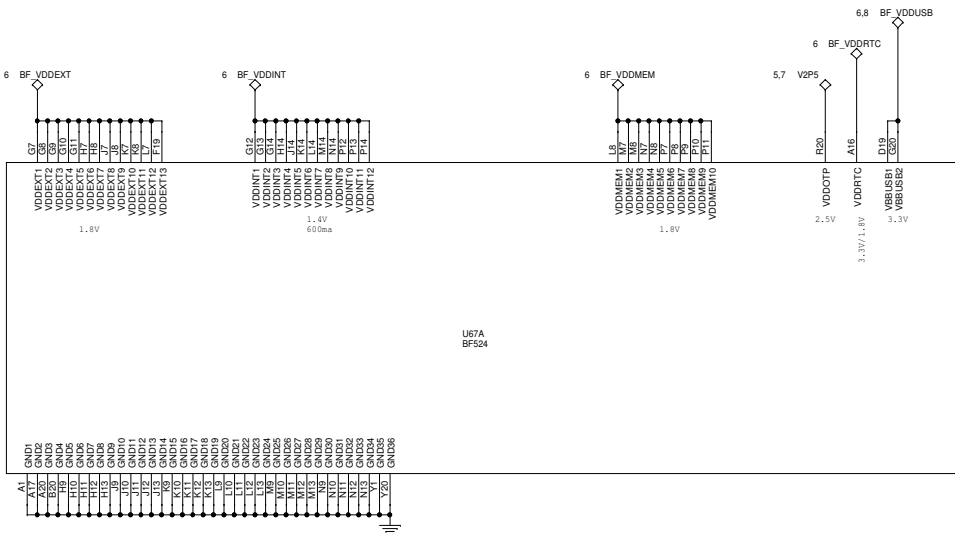
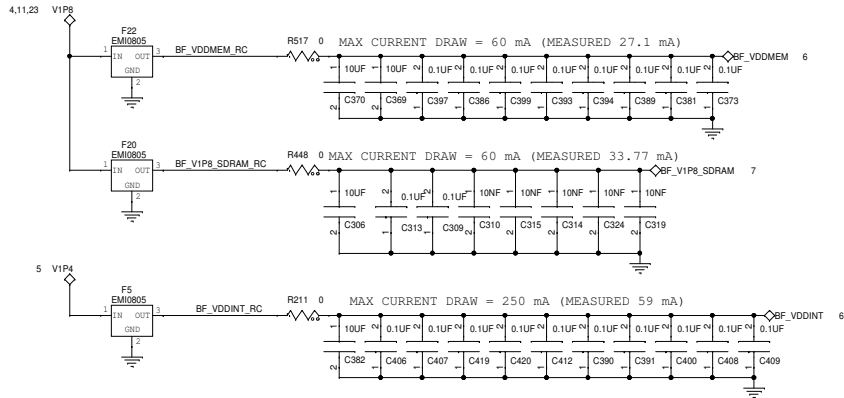
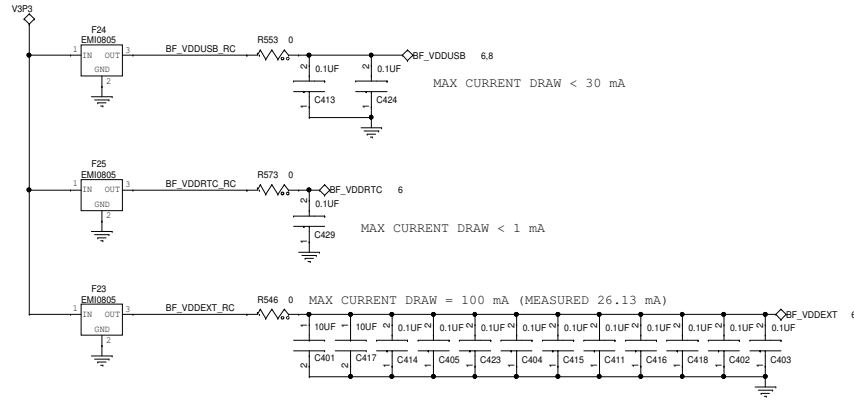

3,4,5,6,7,8,9,10,11,14,15,16,17,18,20,21,22,23,24,25,26,27,28,29,30,31,32,33,34,35,36,37,38,39

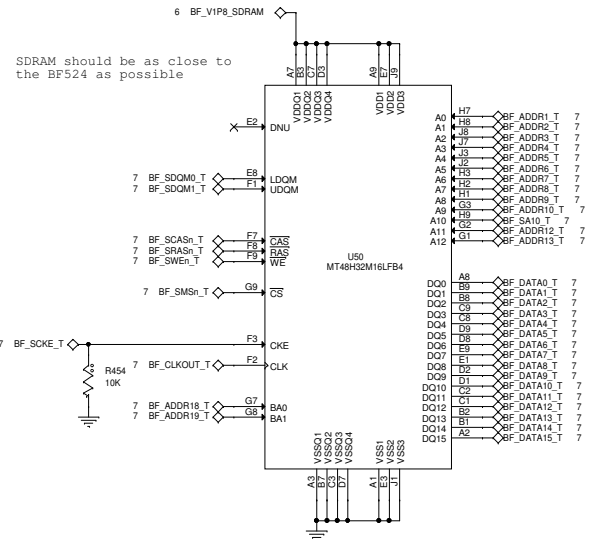
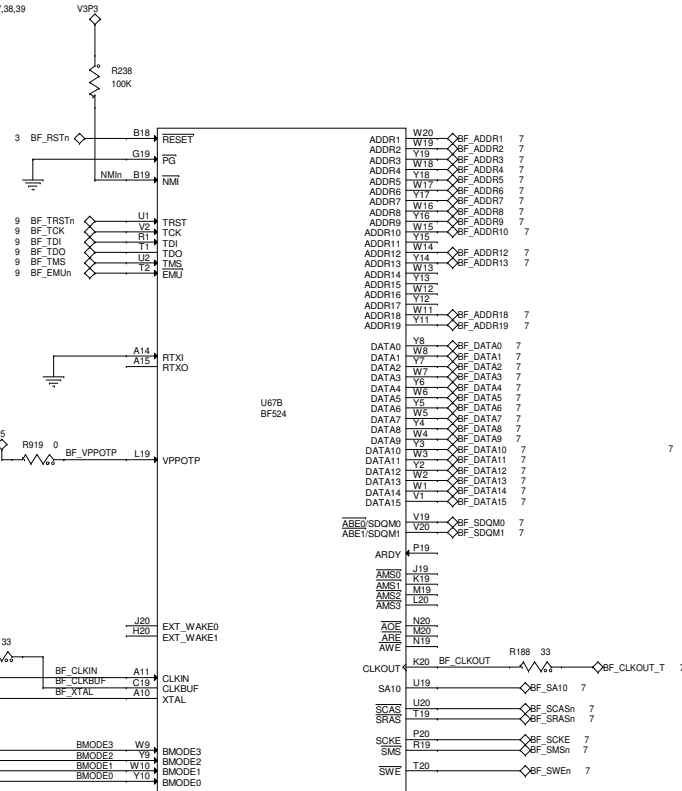

SDRAM should be as close to the BF524 as possible

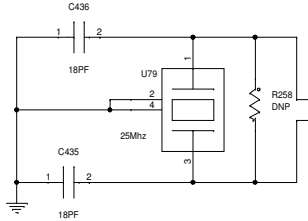

3,4,5,6,7,8,9,10,11,14,15,16,17,18,20,21,22,23,24,25,26,27,28,29,30,31,32,33,34,35,36,37,38,39

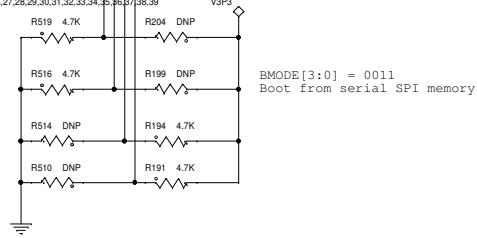

BMODE[3:0] = 0011
Boot from serial SPI memory

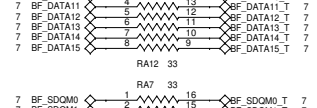
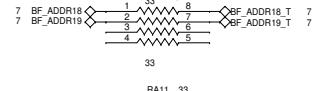
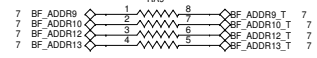
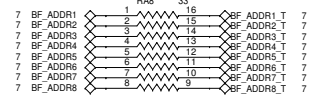

| | | | | | |
|-------|--|-------|-------------|----|-----------------------------|
| Title | | | BF524 SDRAM | | |
| Size | Document Number | Rev | | | 0.2 |
| C | Eval-MELODY-7 Audio/Video Evaluation Board | Date: | | | Wednesday, January 04, 2017 |
| Sheet | | 7 | | of | 40 |

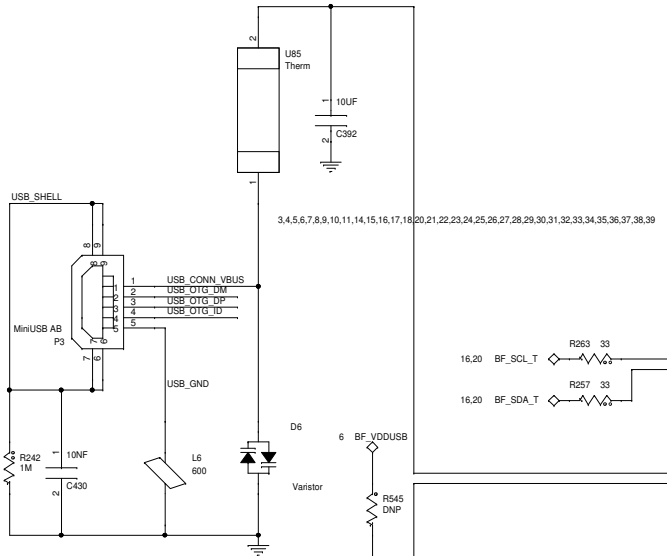

USB_OTG_DM and USB_OTG_DP are differential pairs with 90 ohm impedance and should be as short as possible

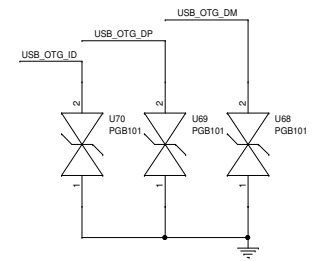

BF_SPI_SEL1: BF524 SERIAL FLASH MEMORY
 BF_SPI_SEL2: ADV7625 SERIAL FLASH MEMORY
 BF_SPI_SEL3: ADSP-21584 SPI0 CS
 BF_SPI_SEL4: AD1939C SPI CS
 BF_SPI_SEL5: UNUSED
 BF_SPI_SEL6: AD1939A SPI CS
 BF_SPI_SEL7: AD1939B SPI CS

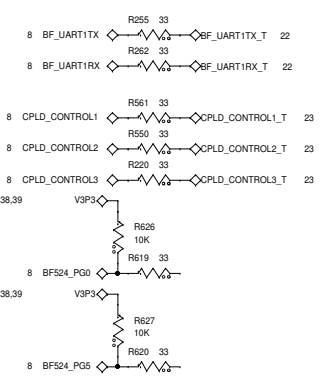
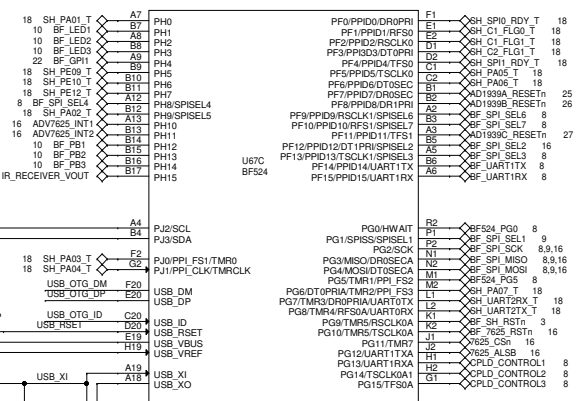
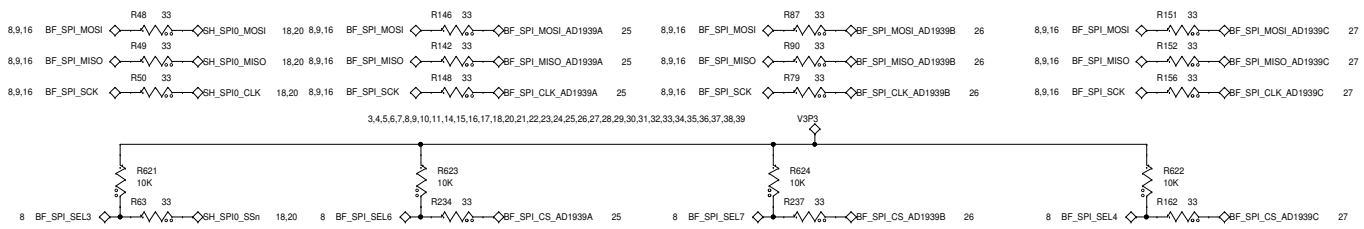

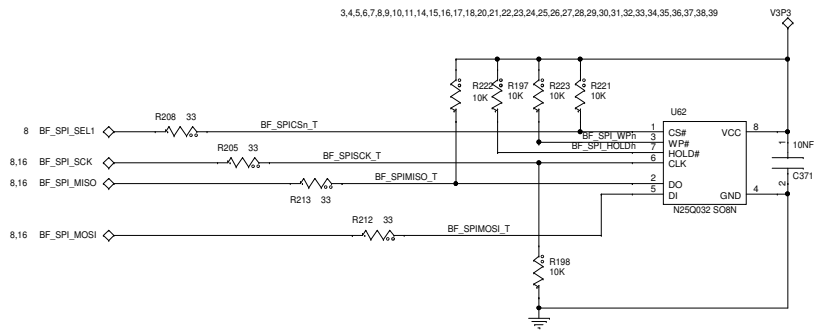
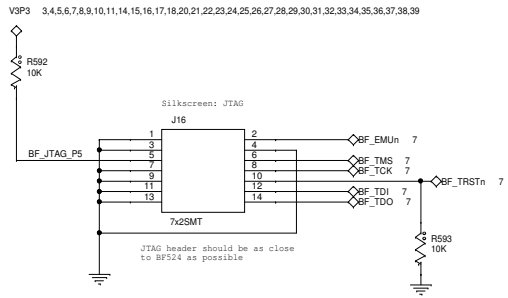

3,4,5,6,7,8,9,10,11,14,15,16,17,18,20,21,22,23,24,25,26,27,28,29,30,31,32,33,34,35,36,37,38,39

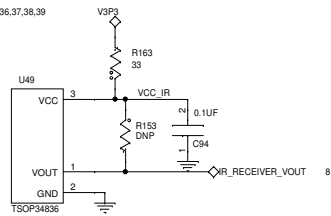

3,4,5,6,7,8,9,10,11,14,15,16,17,18,20,21,22,23,24,25,26,27,28,29,30,31,32,33,34,35,36,37,38,39

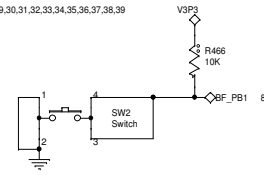

3,4,5,6,7,8,9,10,11,14,15,16,17,18,20,21,22,23,24,25,26,27,28,29,30,31,32,33,34,35,36,37,38,39

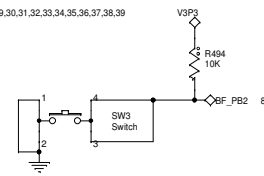

3,4,5,6,7,8,9,10,11,14,15,16,17,18,20,21,22,23,24,25,26,27,28,29,30,31,32,33,34,35,36,37,38,39

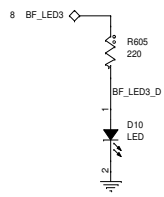
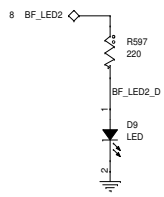
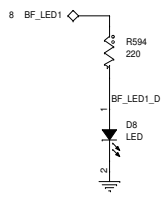
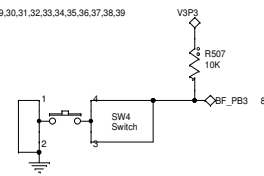

| | | |
|---------------------------|--|----------------|
| Title | | |
| BF524 GP INPUTS / OUTPUTS | | |
| Size | Document Number | Rev |
| C | EVAL-MELODY-7 Audio/Video Evaluation Board | 0.2 |
| Date: | Wednesday, January 04, 2017 | Sheet 10 of 40 |

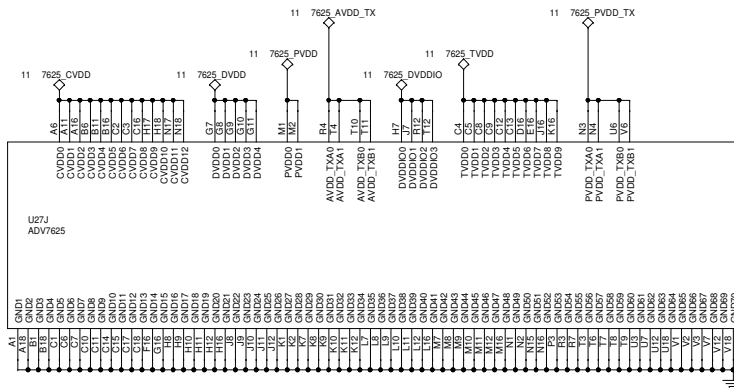
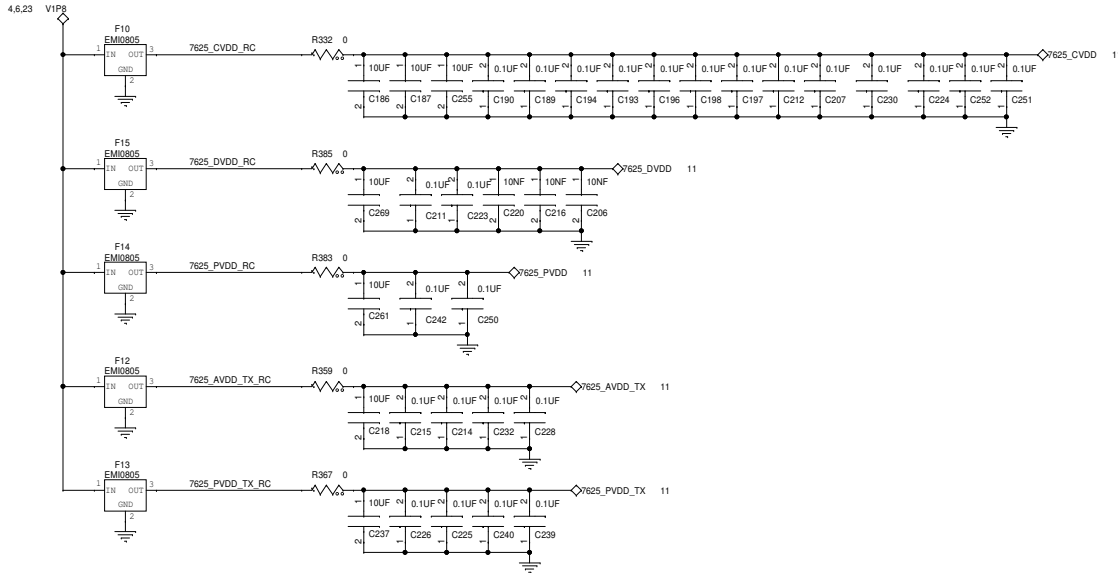
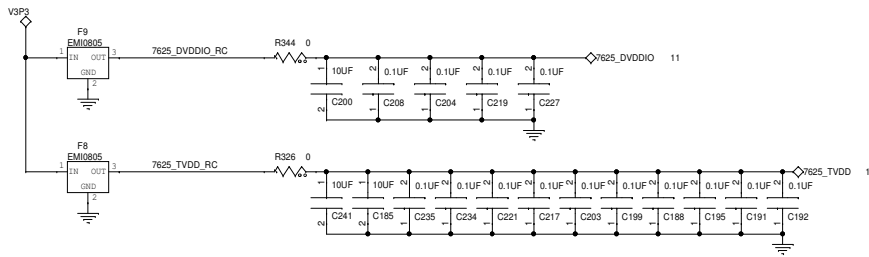

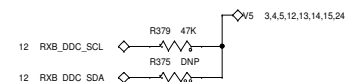
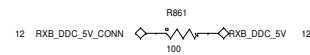
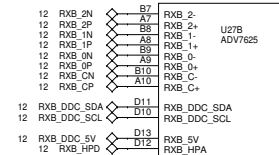
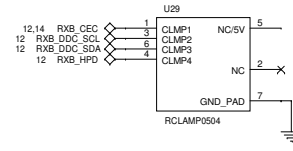
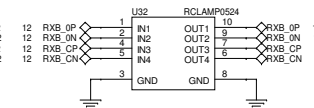
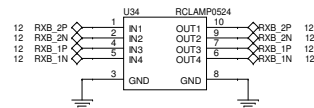
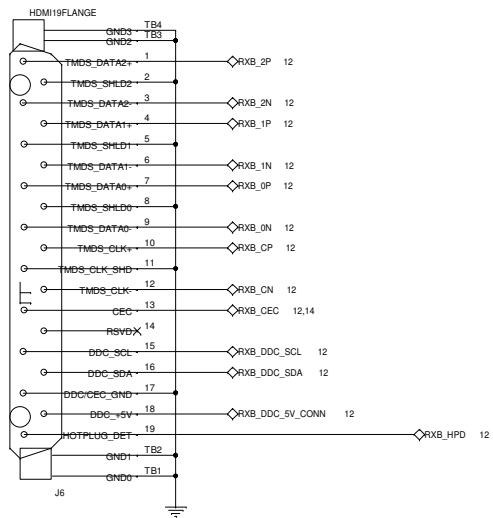
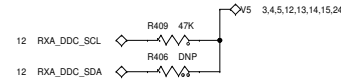
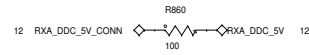
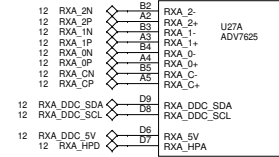
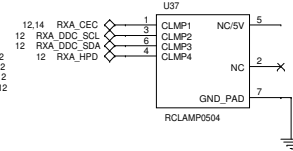
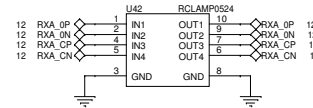
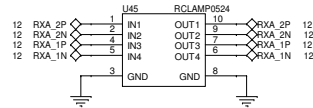
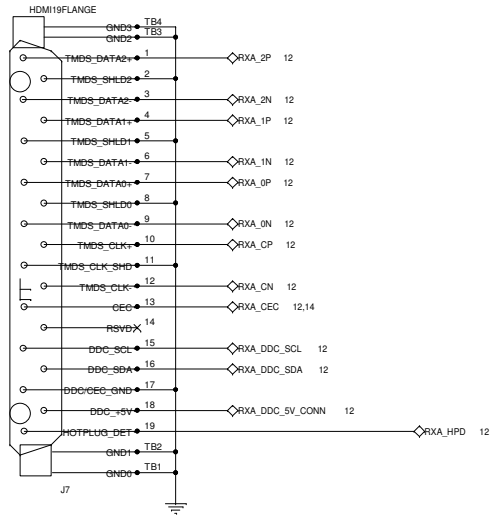

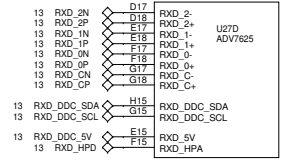
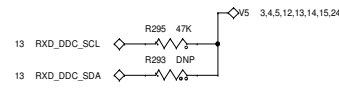
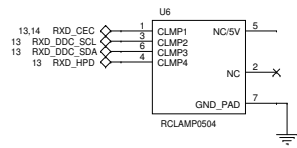
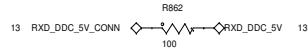
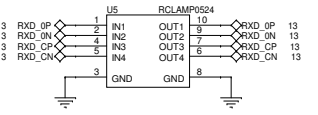
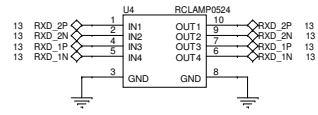
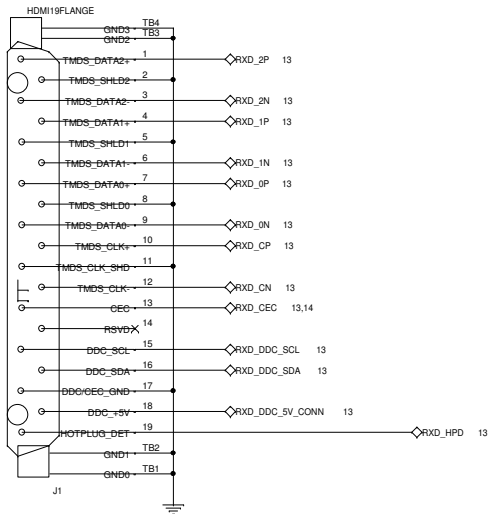
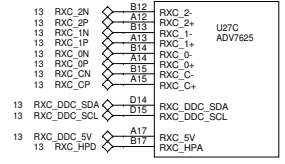
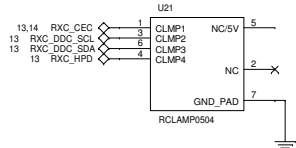
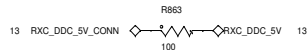
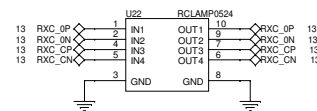
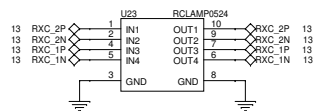
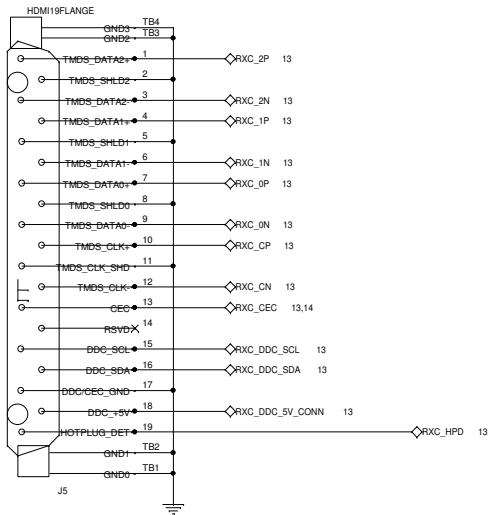

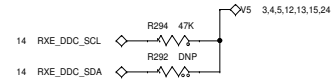
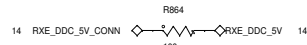
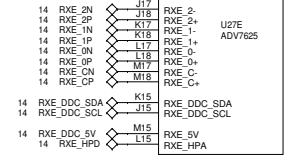
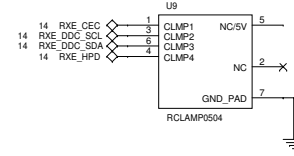
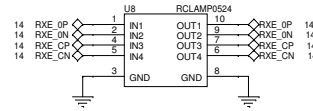
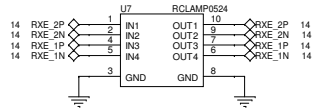
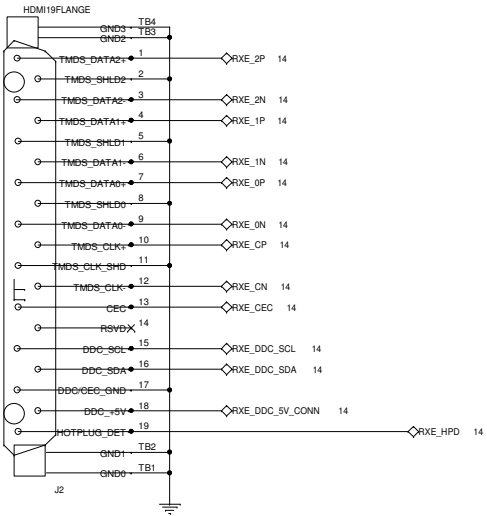

3,4,5,6,7,8,9,10,11,15,16,17,18,20,21,22,23,24,25,26,27,28,29,30,31,32,33,34,35,36,37,38,39

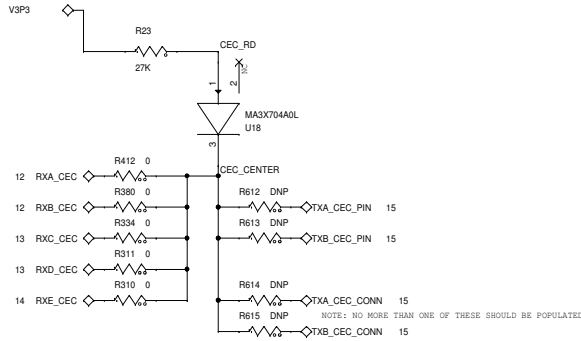

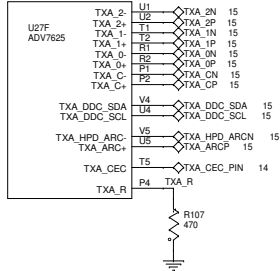

3,4,5,6,7,8,9,10,11,14,15,16,17,18,20,21,22,23,24,25,26,27,28,29,30,31,32,33,34,35,36,37,38,39

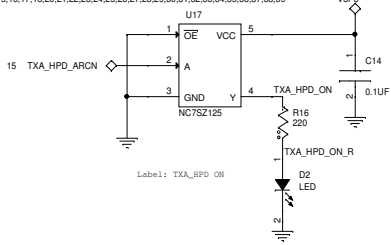

Label: TXA_HPD_ON

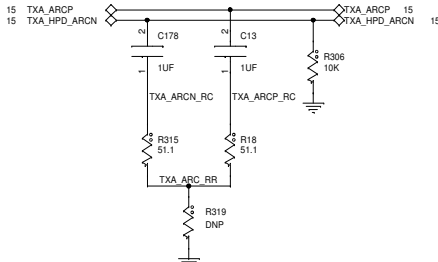
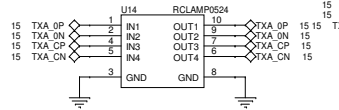
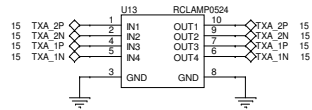

Populate R319 with a 5.1 ohm 0603 if ARC functionality is desired on TXA.

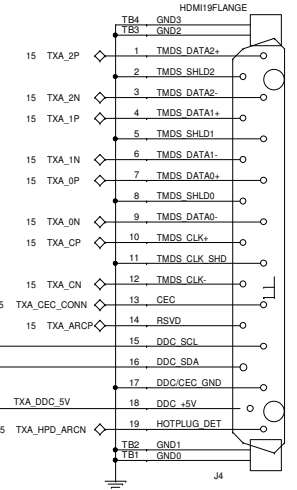
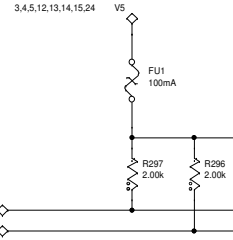
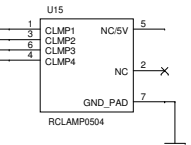

HDMI OUTPUT A

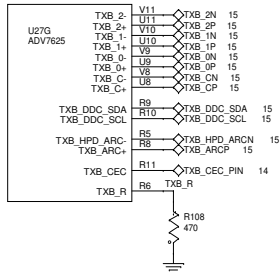

3,4,5,6,7,8,9,10,11,14,15,16,17,18,20,21,22,23,24,25,26,27,28,29,30,31,32,33,34,35,36,37,38,39

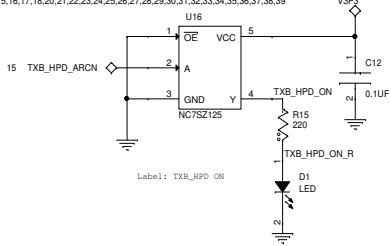

Label: TXB_HPD_ON

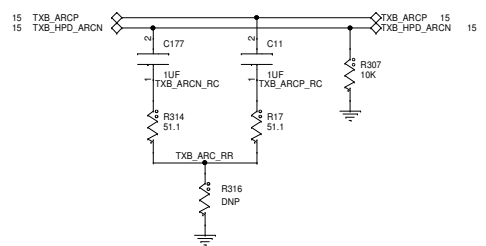
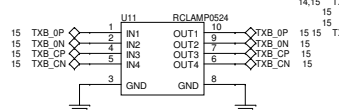
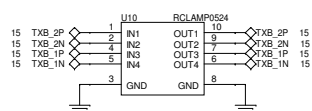

Populate R316 with a 5.1 ohm 0603 if ARC functionality is desired on TXB.

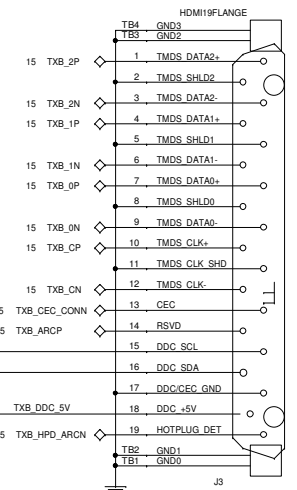
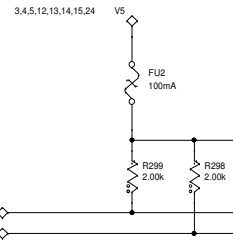
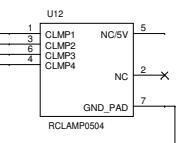

HDMI OUTPUT B

| | | |
|-------------------------|--|----------------|
| Title | | |
| ADV7625 OUTPUTS A AND B | | |
| Size | Document Number | Rev |
| C | EVAL-MELODY-7 Audio/Video Evaluation Board | 0.2 |
| Date: | Wednesday, January 04, 2017 | Sheet 15 of 40 |

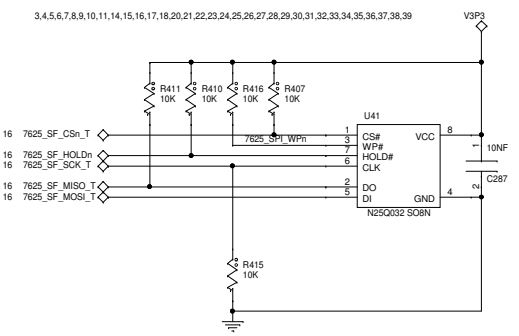
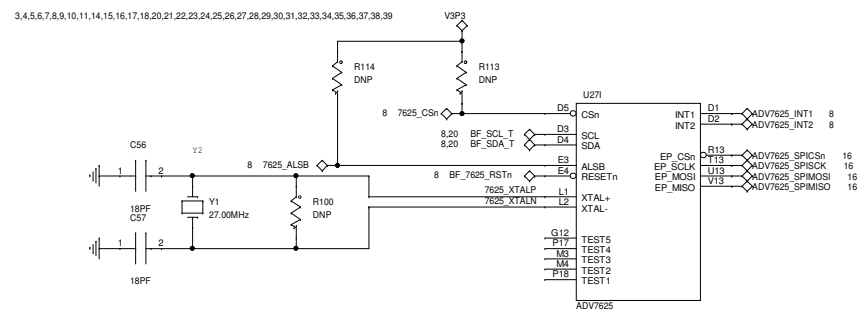
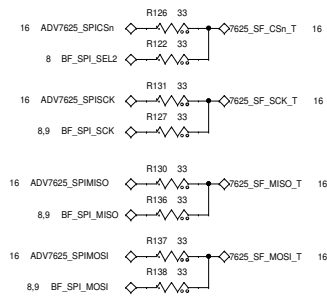
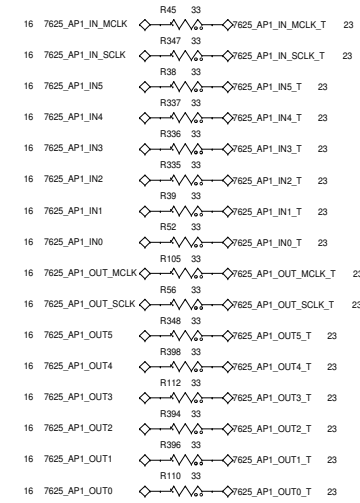
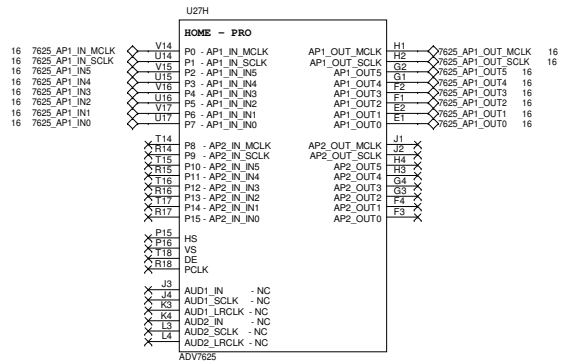

ADV7625 I2C ADDRESS:
 ALSB Low : IO Map address is 0xB0 (default)
 ALSB High : IO Map address is 0xB2

8003-STYLE MASTER SPI HEADER (NOT POPULATED)

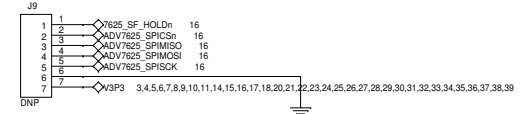

NEED TO CALCULATE VALUES FOR 1.5V

3,4,5,6,7,8,9,10,11,14,15,16,17,18,20,21,22,23,24,25,26,27,28,29,30,31,32,33,34,35,36,37,38,39

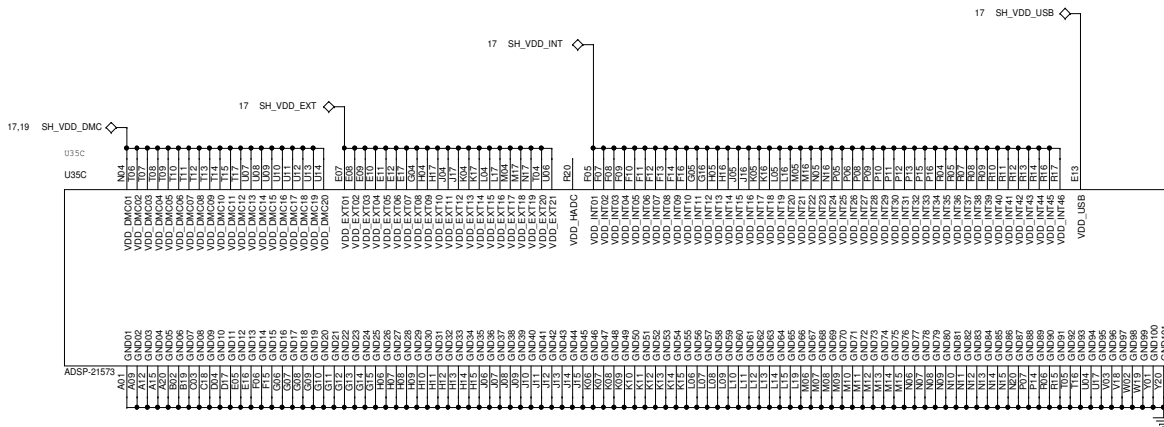
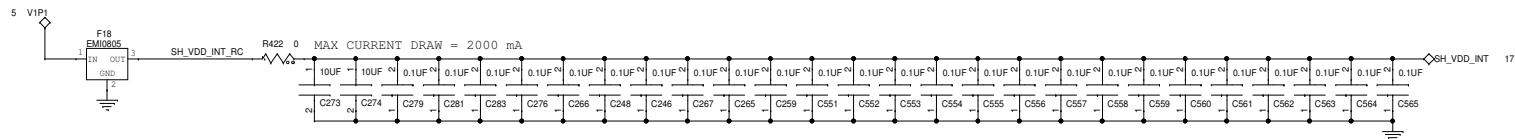
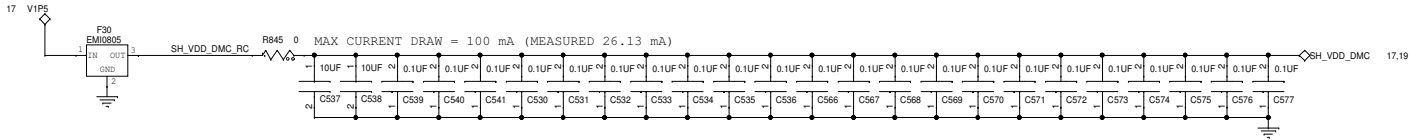
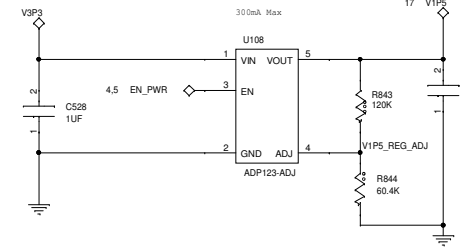
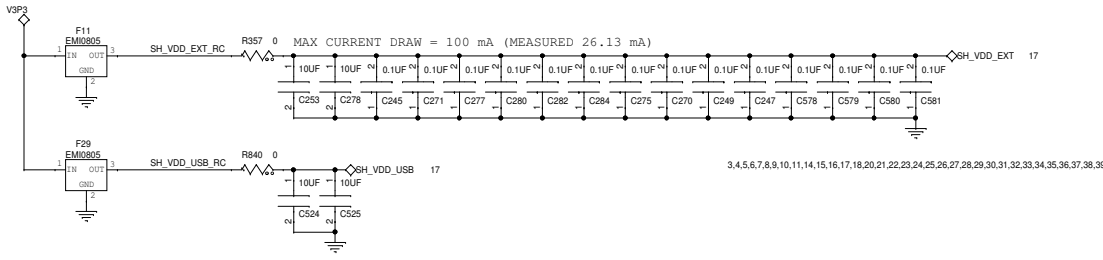

| | | |
|------------------|--|----------------|
| Title | | |
| ADSP-21573 POWER | | |
| Size | Document Number | Rev |
| C | EVAL-MELODY-7 Audio/Video Evaluation Board | 0.2 |
| Date: | Wednesday, January 04, 2017 | Sheet 17 of 40 |

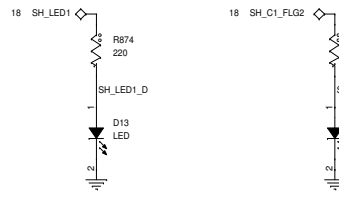
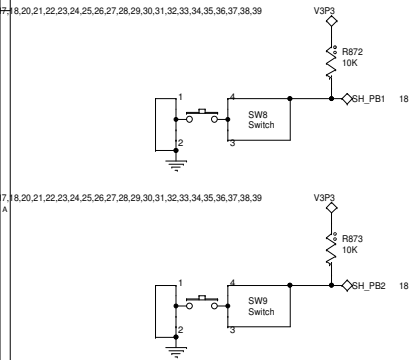
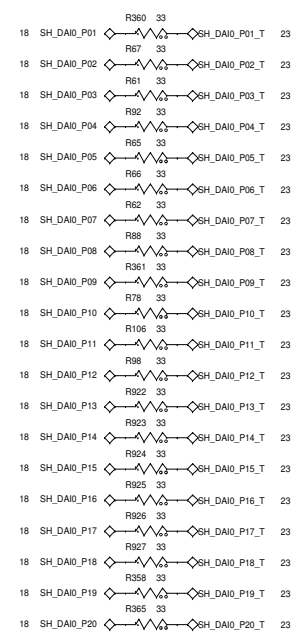
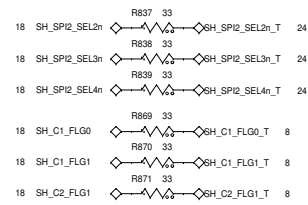
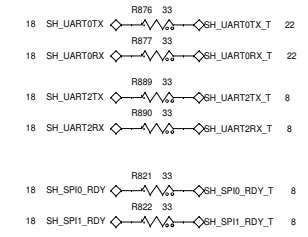
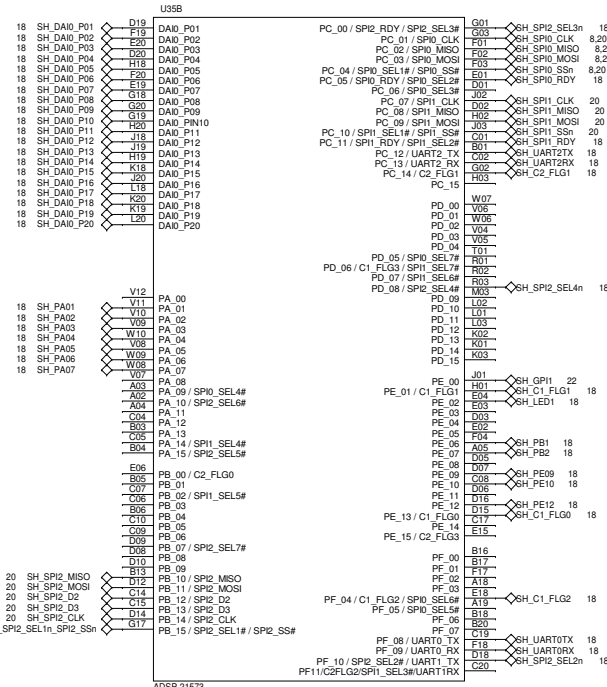

| | | |
|------------------------|--|----------------|
| Title | | |
| ADSP-21573 PERIPHERALS | | |
| Size | Document Number | Rev |
| C | EVAl-MELODY-7 Audio/Video Evaluation Board | 0.2 |
| Date: | Wednesday, January 04, 2017 | Sheet 18 of 40 |

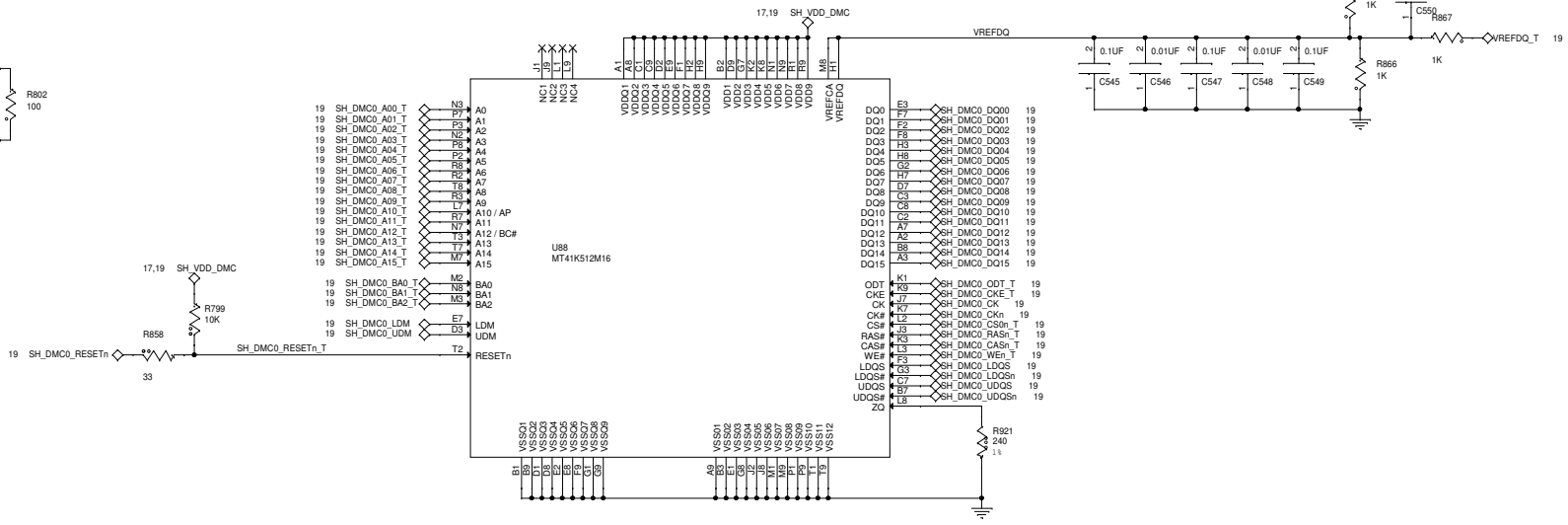
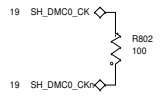
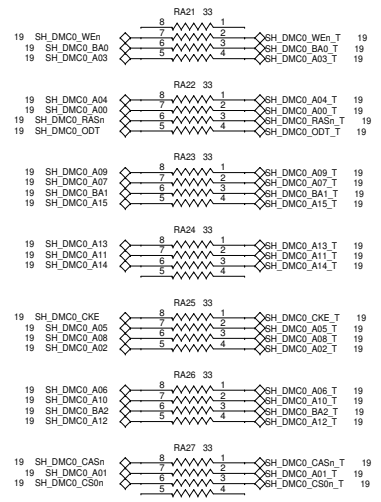
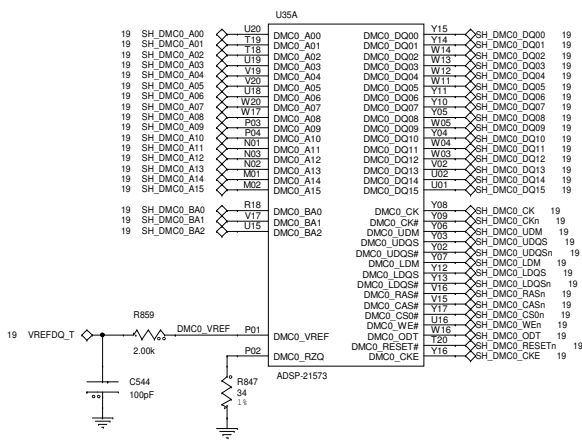

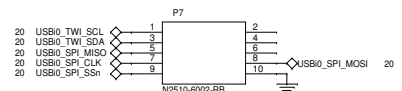
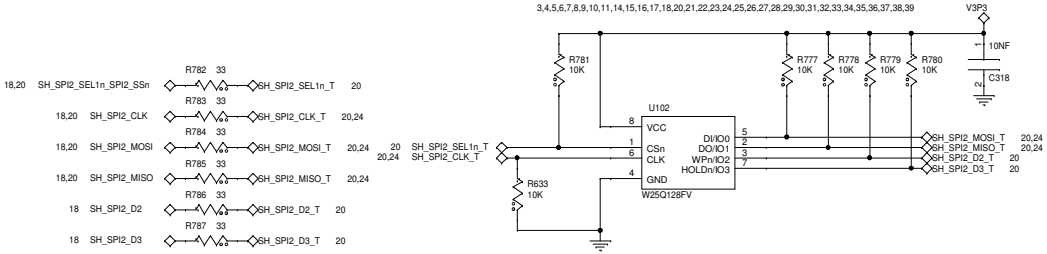
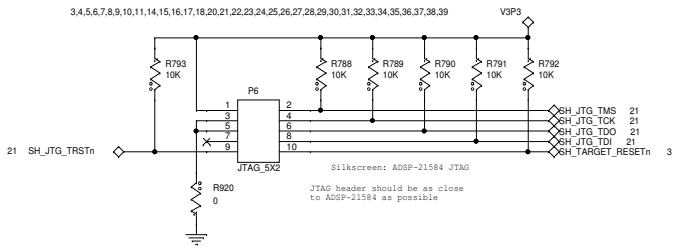

USBi or Aardvark SPI INTERFACE

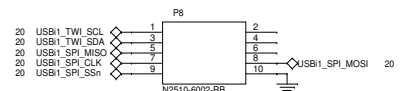
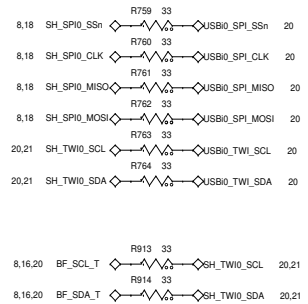

USBi or Aardvark SPI INTERFACE

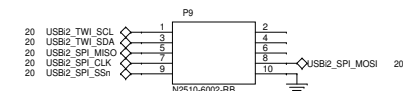
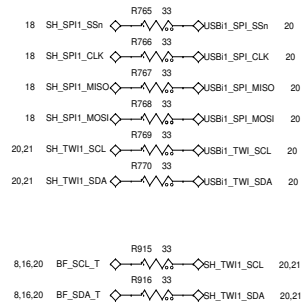

USBi or Aardvark SPI INTERFACE

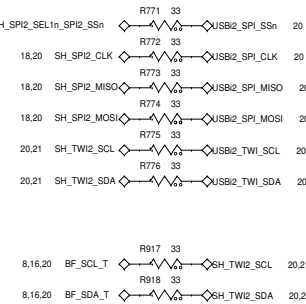

| | | | |
|-------|-----------------------------|--|-------------------------|
| Title | | | ADSP-21573 FLASH / JTAG |
| Size | Document Number | EVAL-MELODY-7 Audio/Video Evaluation Board | |
| C | | | Rev 0.2 |
| Date: | Wednesday, January 04, 2017 | Sheet | 20 of 40 |

3,4,5,6,7,8,9,10,11,14,15,16,17,18,20,21,22,23,24,25,26,27,28,29,30,31,32,33,34,35,36,37,38,39

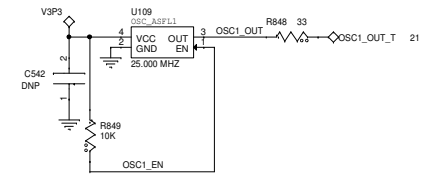

3,4,5,6,7,8,9,10,11,14,15,16,17,18,20,21,22,23,24,25,26,27,28,29,30,31,32,33,34,35,36,37,38,39

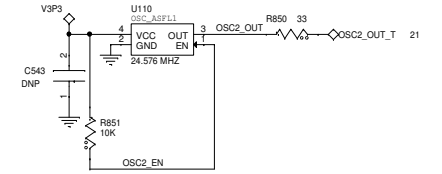

3,4,5,6,7,8,9,10,11,14,15,16,17,18,20,21,22,23,24,25,26,27,28,29,30,31,32,33,34,35,36,37,38,39

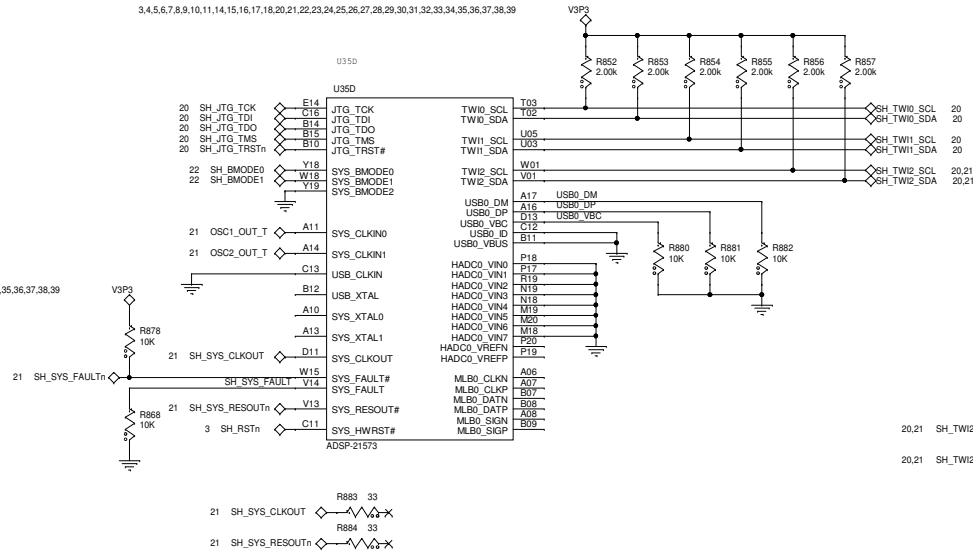

3,4,5,6,7,8,9,10,11,14,15,16,17,18,20,21,22,23,24,25,26,27,28,29,30,31,32,33,34,35,36,37,38,39

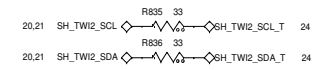

3,4,5,6,7,8,9,10,11,14,15,16,17,18,20,21,22,23,24,25,26,27,28,29,30,31,32,33,34,35,36,37,38,39

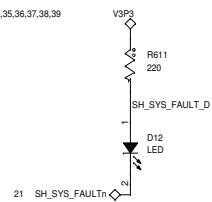

| | | |
|-------------------|--|----------------|
| Title | | |
| ADSP-21573 SYSTEM | | |
| Size | Document Number | Rev |
| C | EVAL-MELODY-7 Audio/Video Evaluation Board | 0.2 |
| Date: | Wednesday, January 04, 2017 | Sheet 21 of 40 |

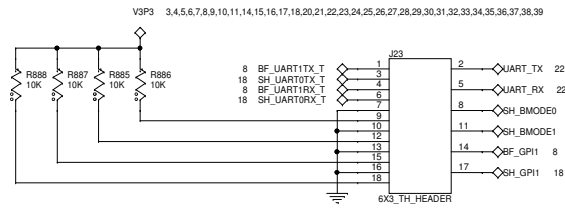

SH_BMODE[1:0] BOOT SOURCE
 00 NO BOOT / CUSTOM ROM
 01 SPI2 MASTER BOOT
 10 SPI2 SLAVE BOOT

3,4,5,6,7,8,9,10,11,14,15,16,17,18,20,21,22,23,24,25,26,27,28,29,30,31,32,33,34,35,36,37,38,39

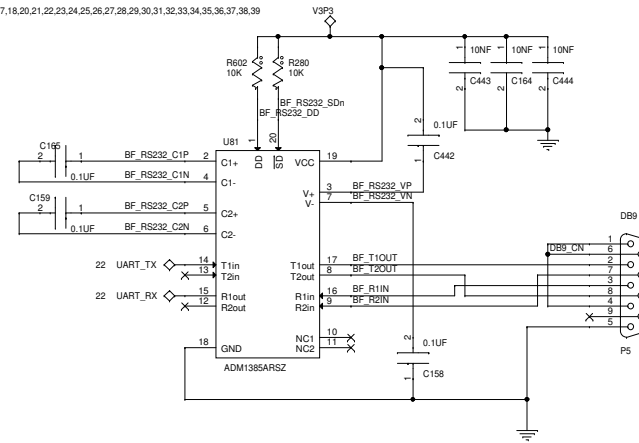

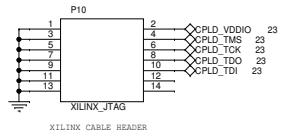
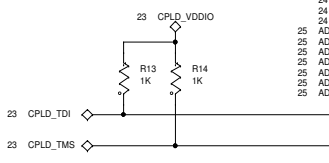
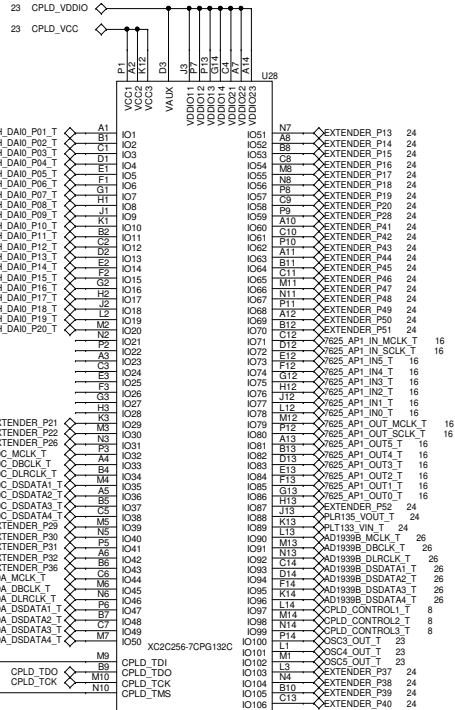
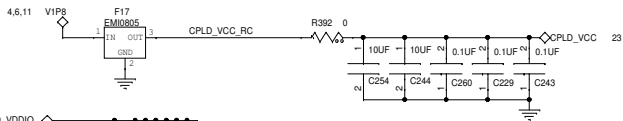
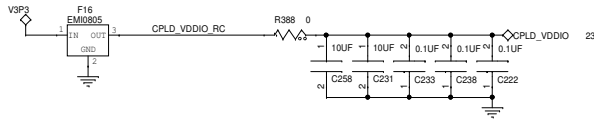

3,4,5,6,7,8,9,10,11,14,15,16,17,18,20,21,22,23,24,25,26,27,28,29,30,31,32,33,34,35,36,37,38,39

3,4,5,6,7,8,9,10,11,14,15,16,17,18,20,21,22,23,24,25,26,27,28,29,30,31,32,33,34,35,36,37,38,39

3,4,5,6,7,8,9,10,11,14,15,16,17,18,20,21,22,23,24,25,26,27,28,29,30,31,32,33,34,35,36,37,38,39

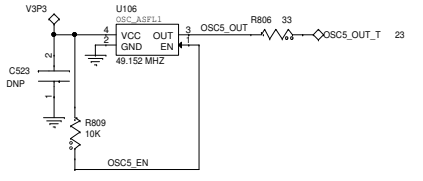
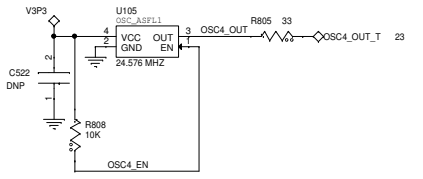
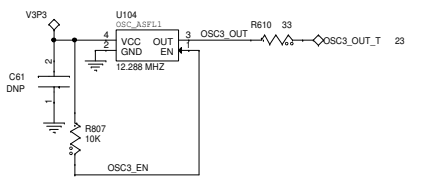

| | | |
|-------|--|----------------|
| Title | | |
| CPLD | | |
| Size | Document Number | Rev |
| C | EVAL-MELODY-7 Audio/Video Evaluation Board | 0.2 |
| Date: | Wednesday, January 04, 2017 | Sheet 23 of 40 |

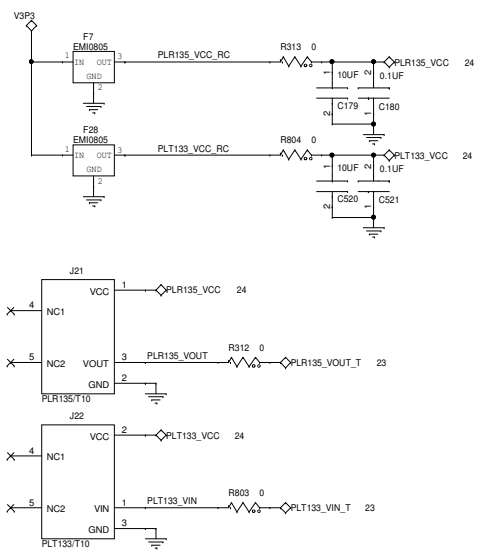
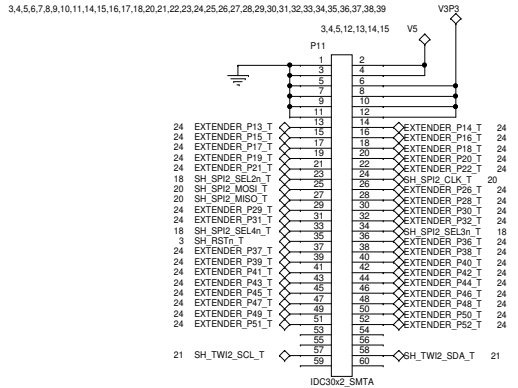
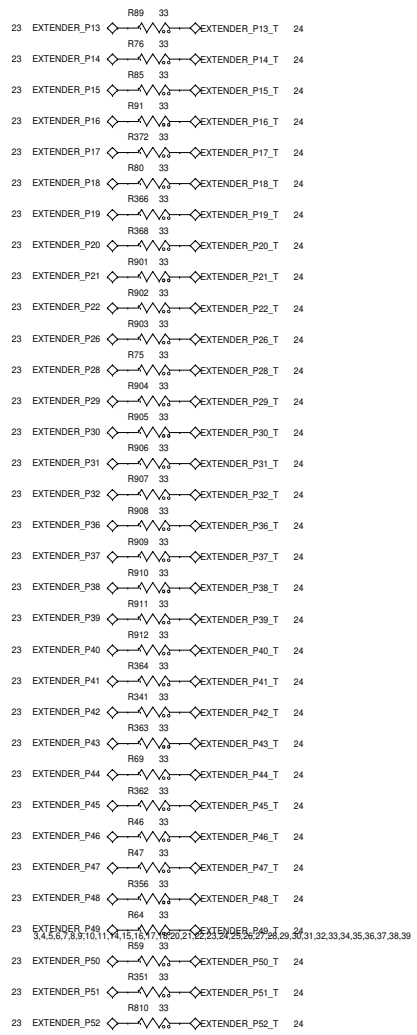

| | | | |
|-------|-----------------------------|--|----------|
| Title | | 60-PIN E12 CONNECTOR | |
| Size | Document Number | EVAL-MELODY-7 Audio/Video Evaluation Board | |
| C | | | Rev 0.2 |
| Date: | Wednesday, January 04, 2017 | Sheet | 24 of 40 |

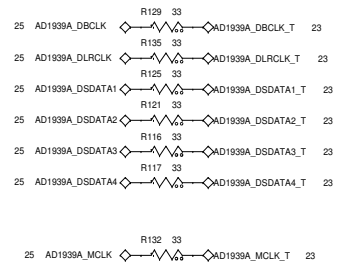
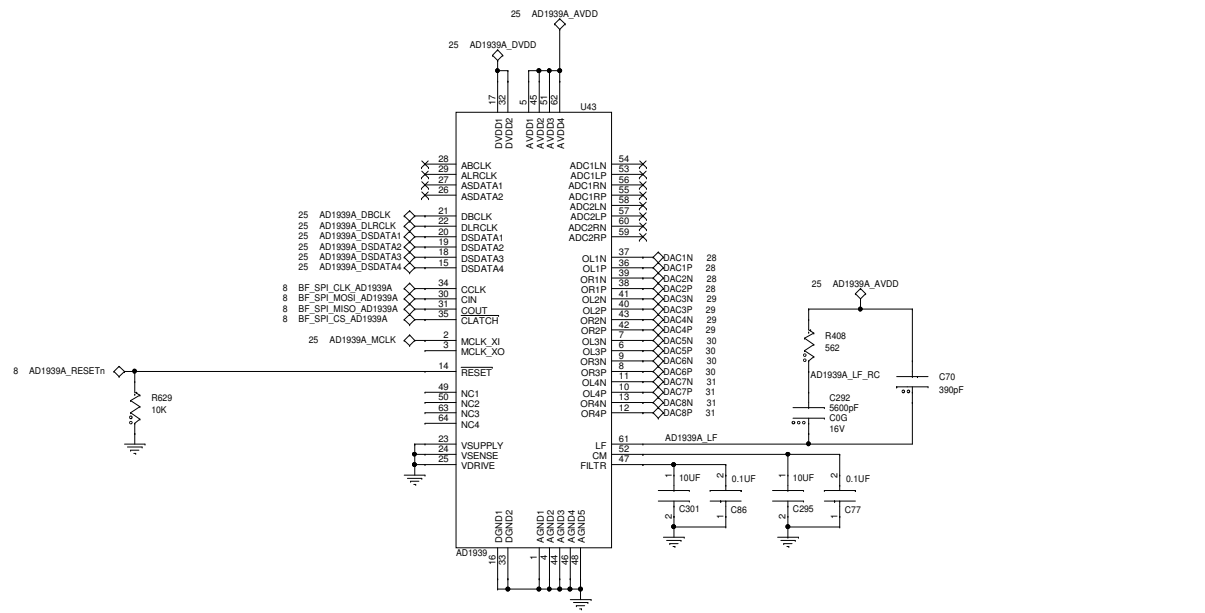
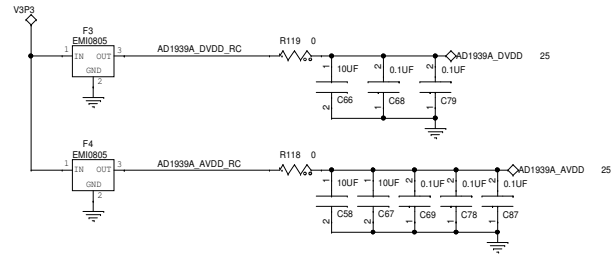

| | | |
|----------------|--|----------------|
| Title | | |
| AD1939 CODEC A | | |
| Size | Document Number | Rev |
| C | EVAL-MELODY-7 Audio/Video Evaluation Board | 0.2 |
| Date: | Wednesday, January 04, 2017 | Sheet 25 of 40 |

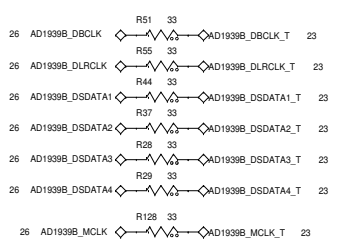
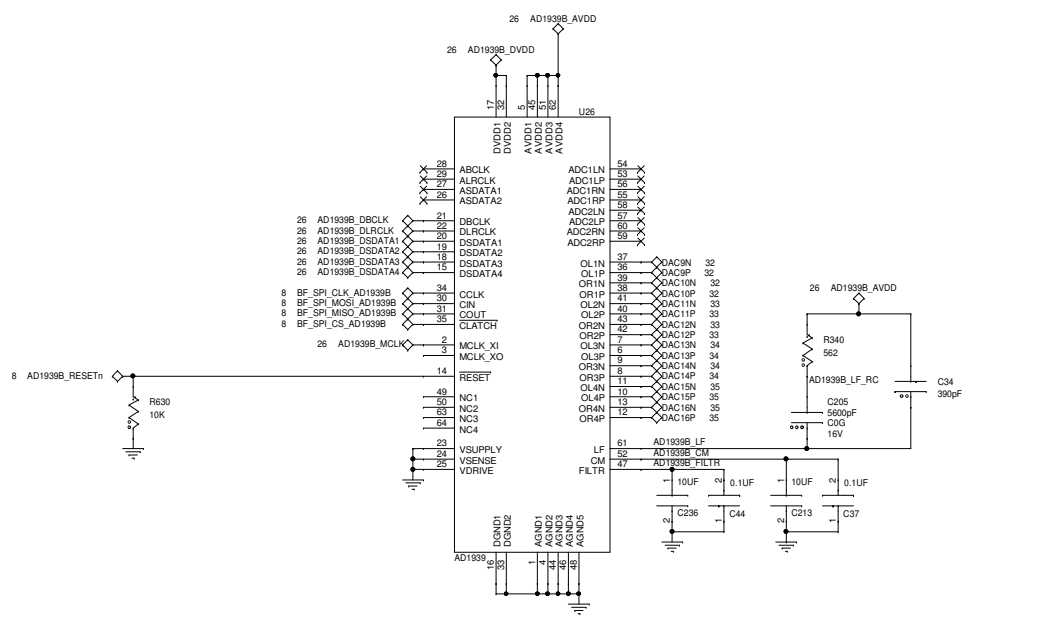
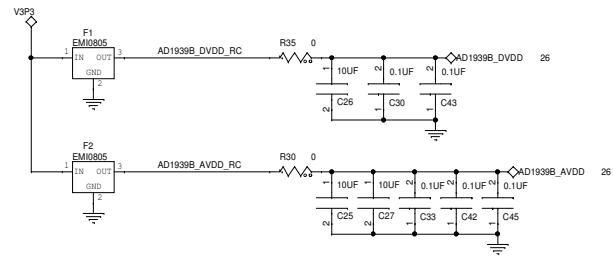

| | | |
|----------------|--|----------------|
| Title | | |
| AD1939 CODEC B | | |
| Size | Document Number | Rev |
| C | EVAL-MELODY-7 Audio/Video Evaluation Board | 0.2 |
| Date: | Wednesday, January 04, 2017 | Sheet 26 of 40 |

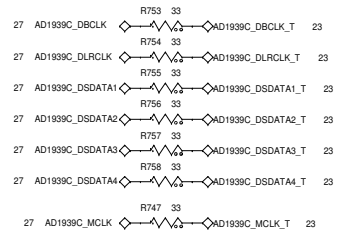
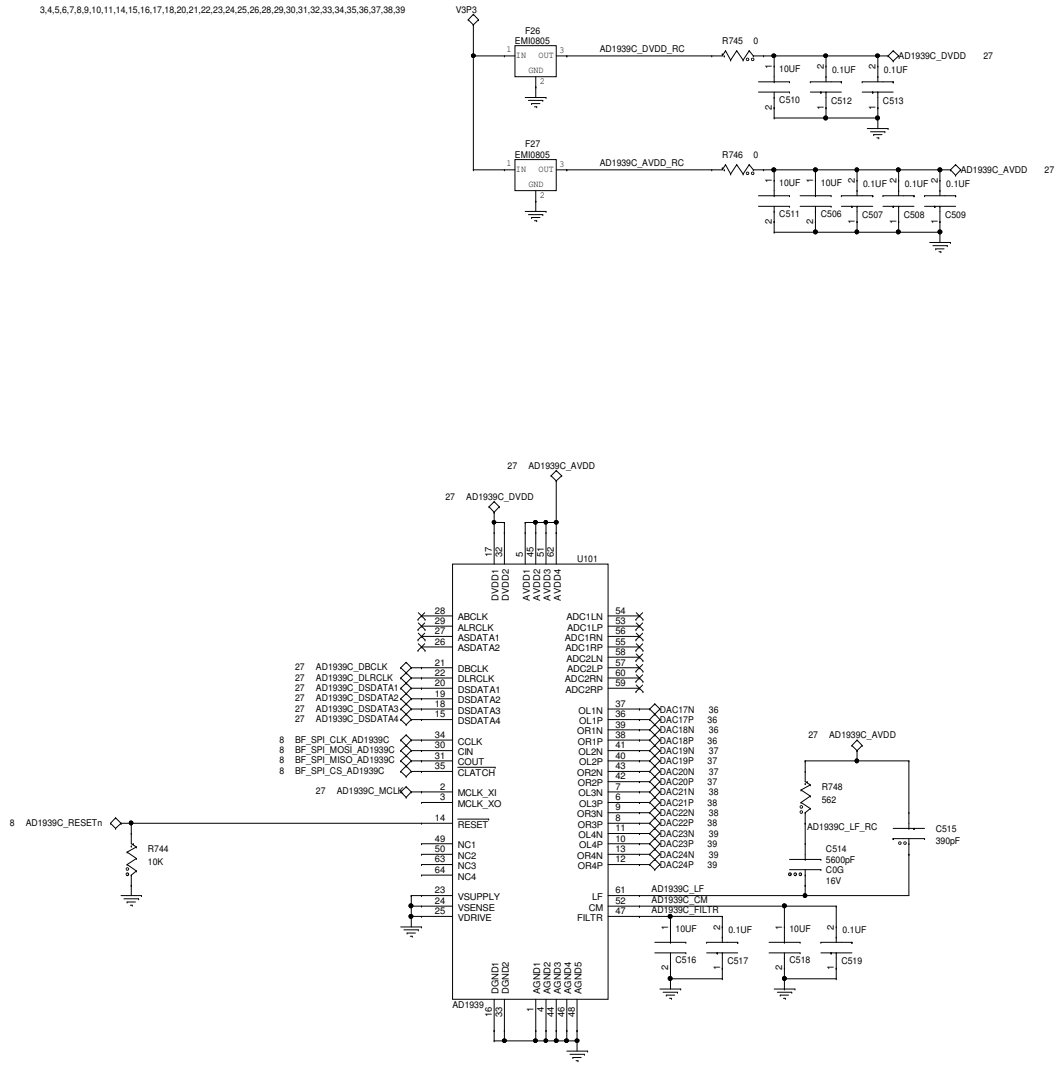

| | | |
|----------------|--|----------------|
| Title | | |
| AD1939 CODEC C | | |
| Size | Document Number | Rev |
| C | EVAl-MELODY-7 Audio/Video Evaluation Board | 0.2 |
| Date: | Wednesday, January 04, 2017 | Sheet 27 of 40 |

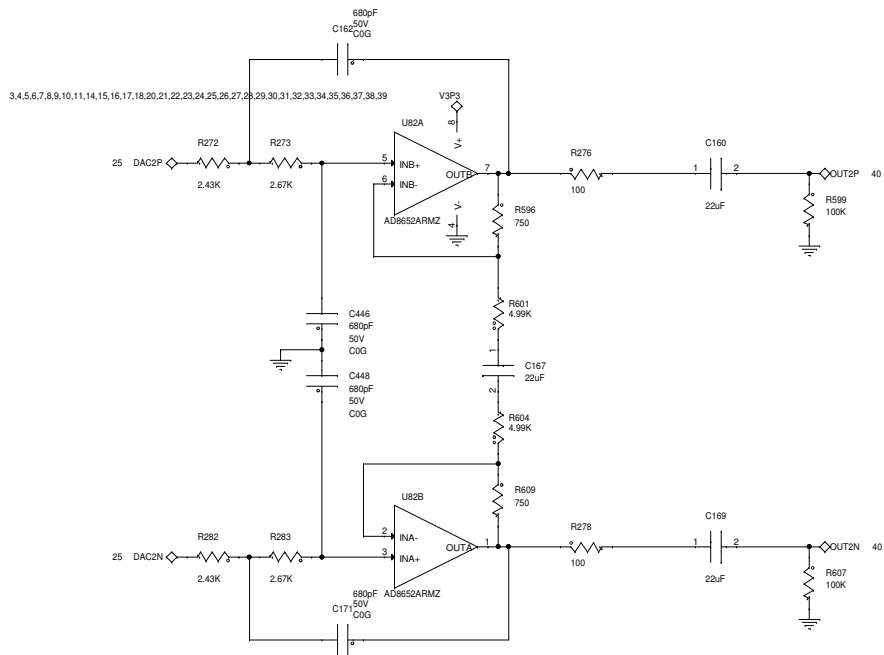
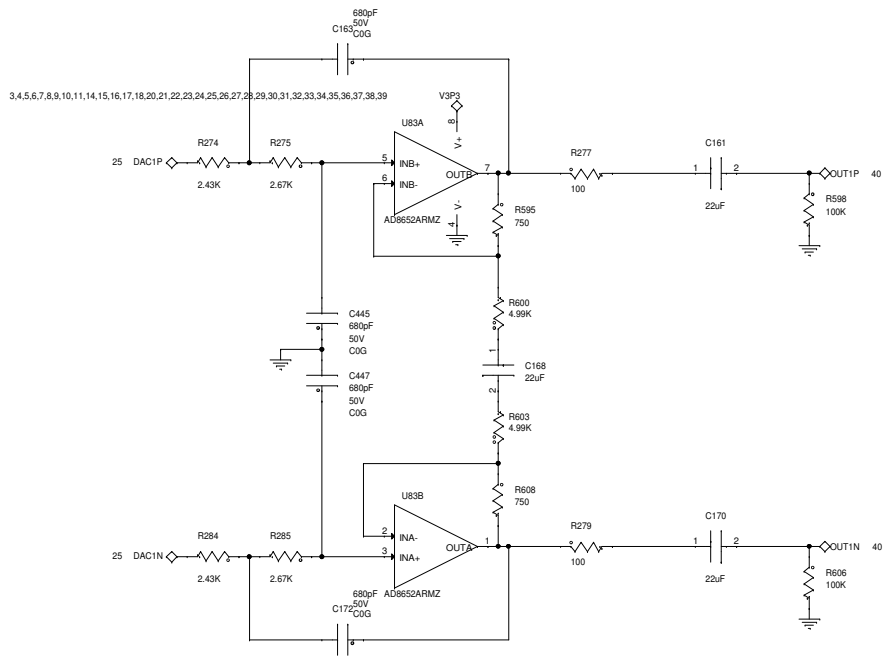

| | | |
|-------------|--|----------------|
| Title | | |
| OUT1 / OUT2 | | |
| Size | Document Number | Rev |
| C | EVAL-MELODY-7 Audio/Video Evaluation Board | 0.2 |
| Date: | Wednesday, January 04, 2017 | Sheet 28 of 40 |

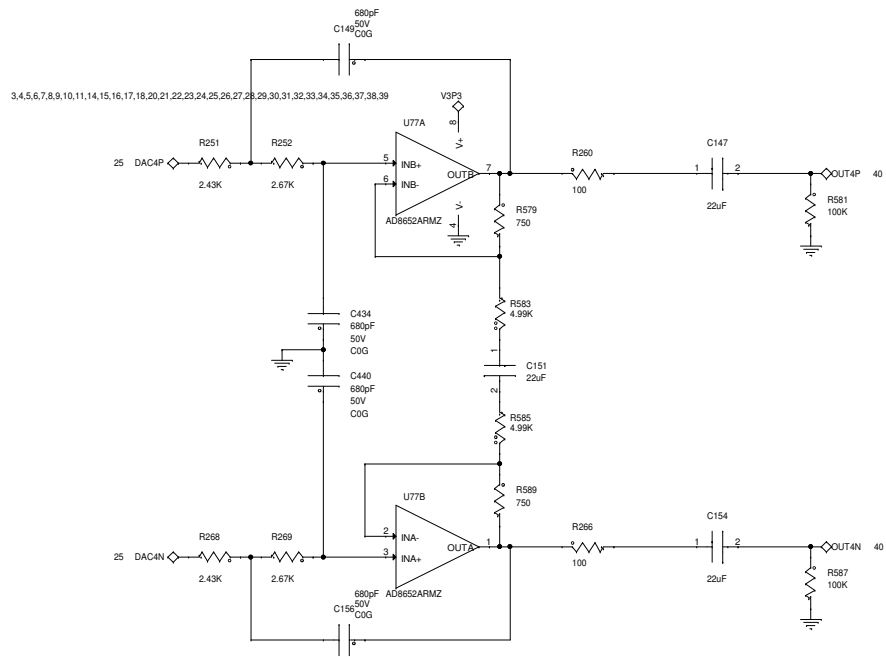
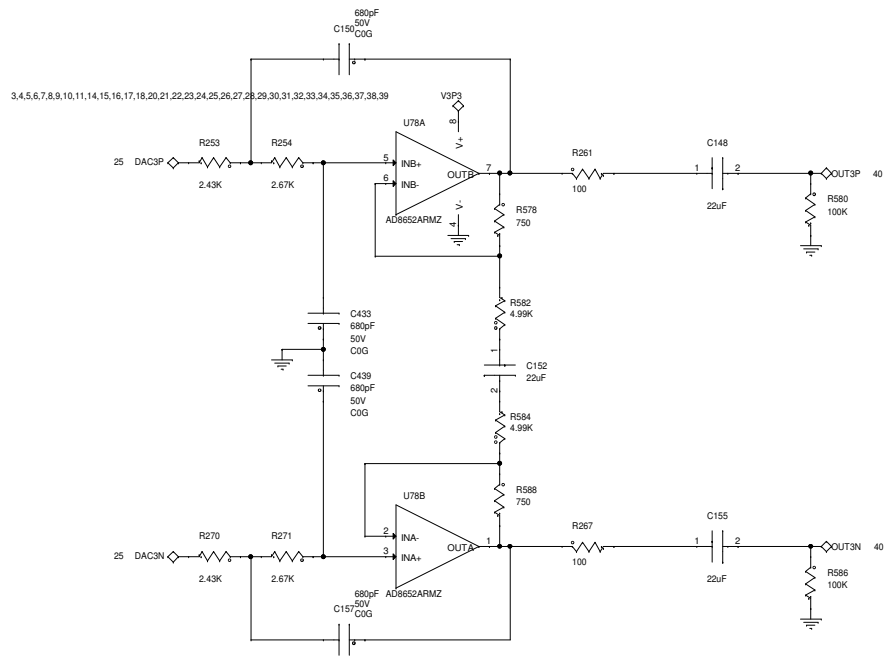

| | | | |
|-------|--|-------------|----------|
| Title | | OUT3 / OUT4 | |
| Size | Document Number | Rev | |
| C | EVAL-MELODY-7 Audio/Video Evaluation Board | 0.2 | |
| Date: | Wednesday, January 04, 2017 | Sheet | 29 of 40 |

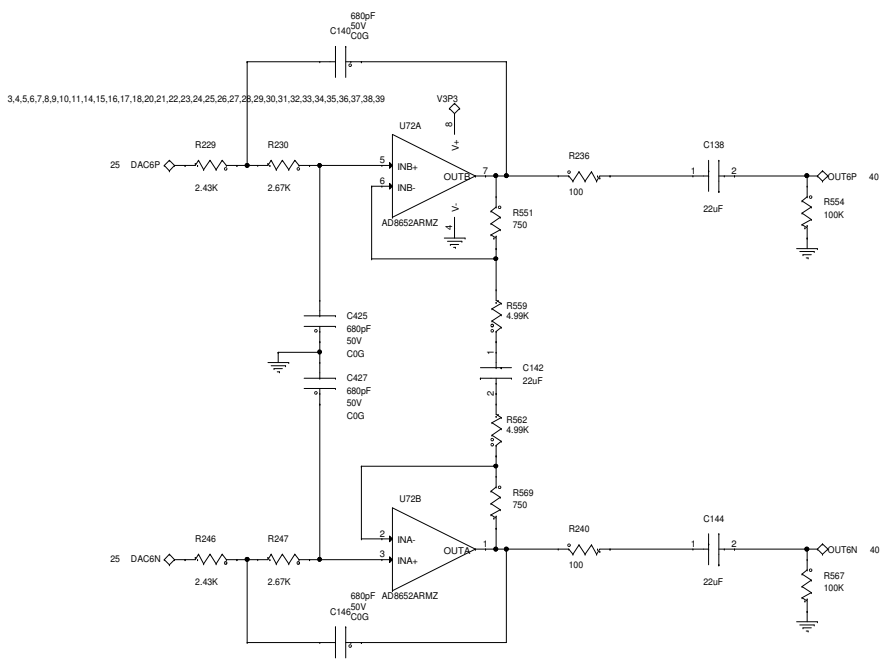
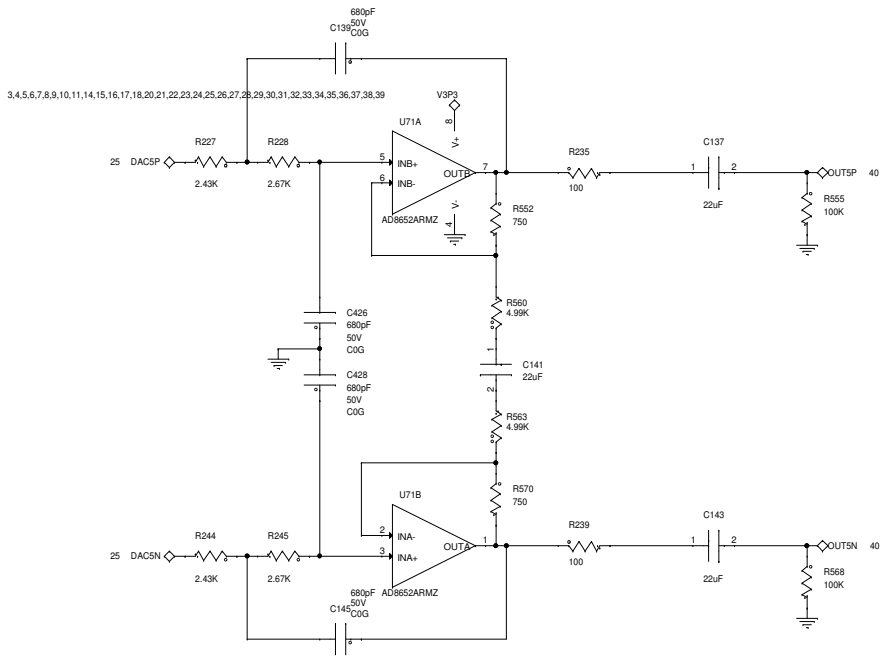

| | | |
|-------------|--|----------------|
| Title | | |
| OUT5 / OUT6 | | |
| Size | Document Number | Rev |
| C | EVAl-MELODY-7 Audio/Video Evaluation Board | 0.2 |
| Date: | Wednesday, January 04, 2017 | Sheet 30 of 40 |

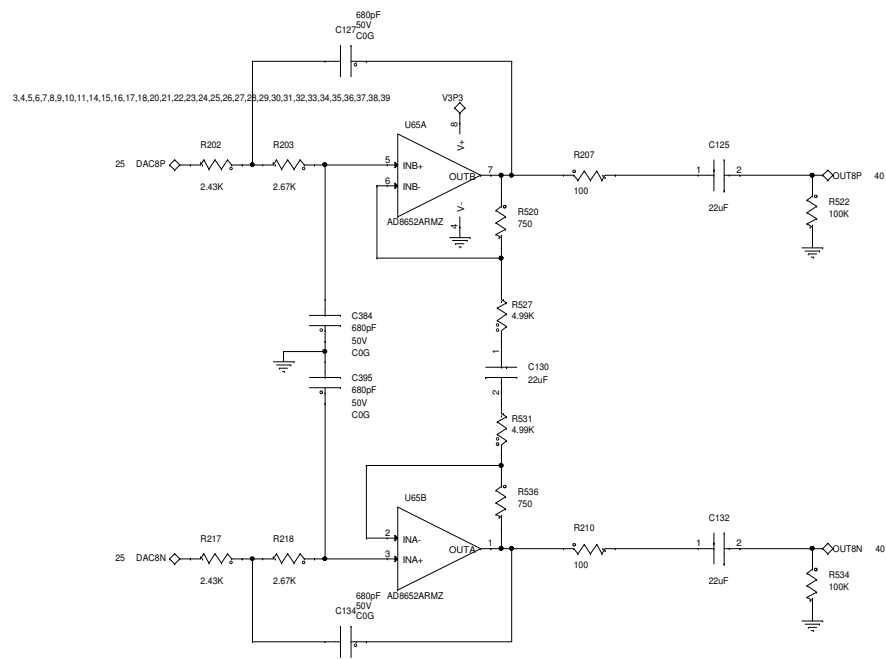
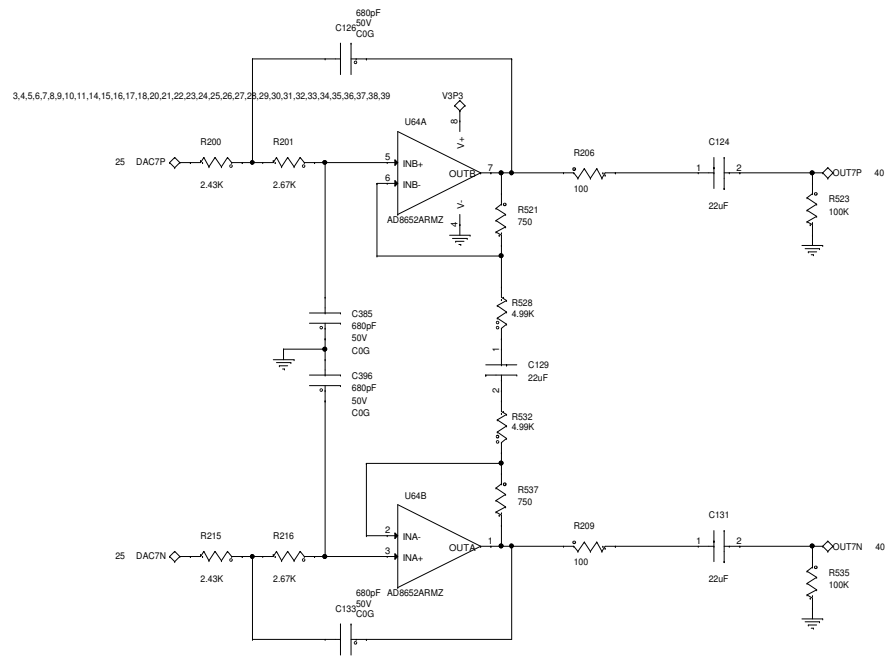

| | | |
|-------------|--|----------------|
| Title | | |
| OUT7 / OUT8 | | |
| Size | Document Number | Rev |
| C | EVAL-MELODY-7 Audio/Video Evaluation Board | 0.2 |
| Date: | Wednesday, January 04, 2017 | Sheet 31 of 40 |

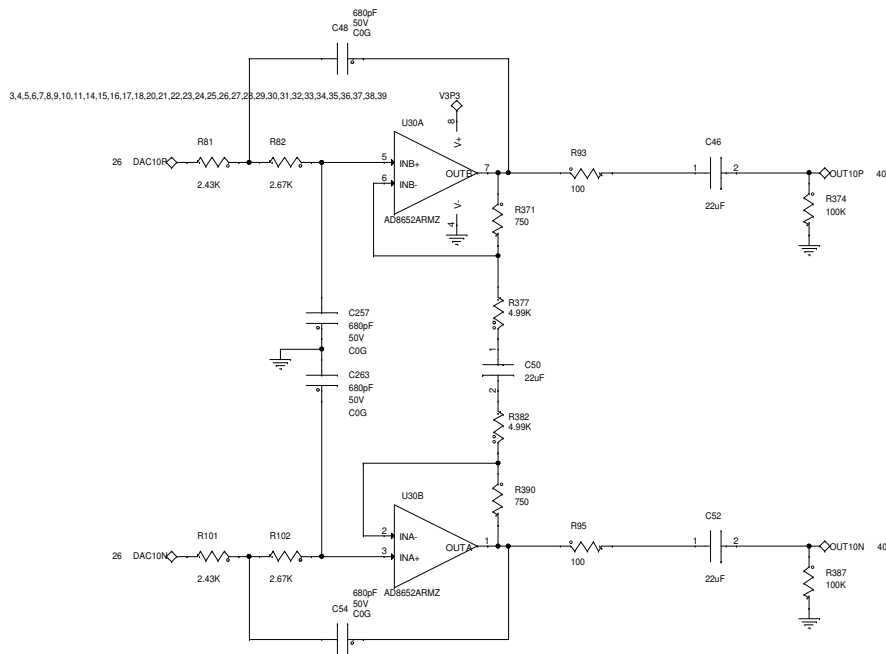
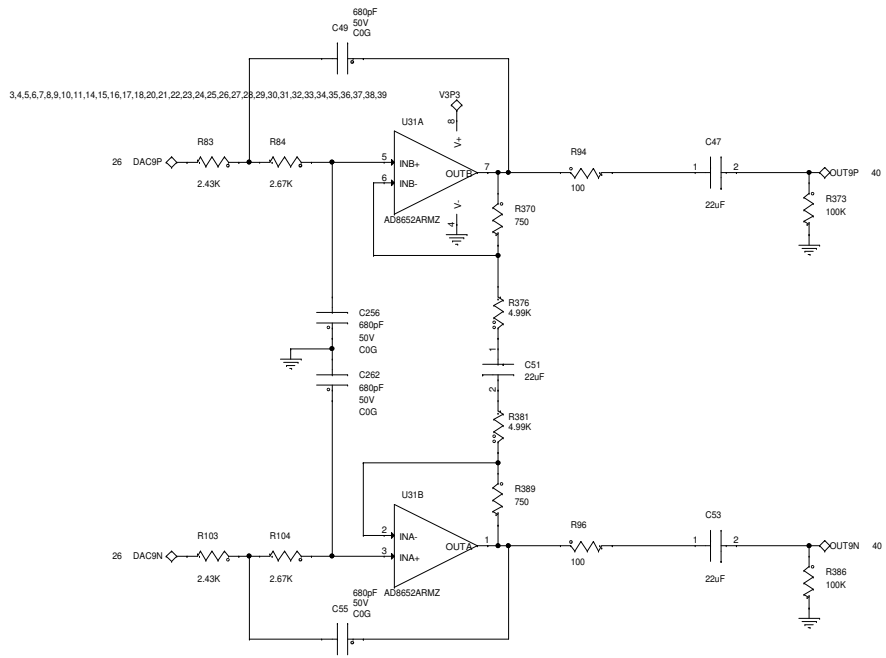

| | | |
|--------------|--|----------------|
| Title | | |
| OUT9 / OUT10 | | |
| Size | Document Number | Rev |
| C | EVAL-MELODY-7 Audio/Video Evaluation Board | 0.2 |
| Date: | Wednesday, January 04, 2017 | Sheet 32 of 40 |

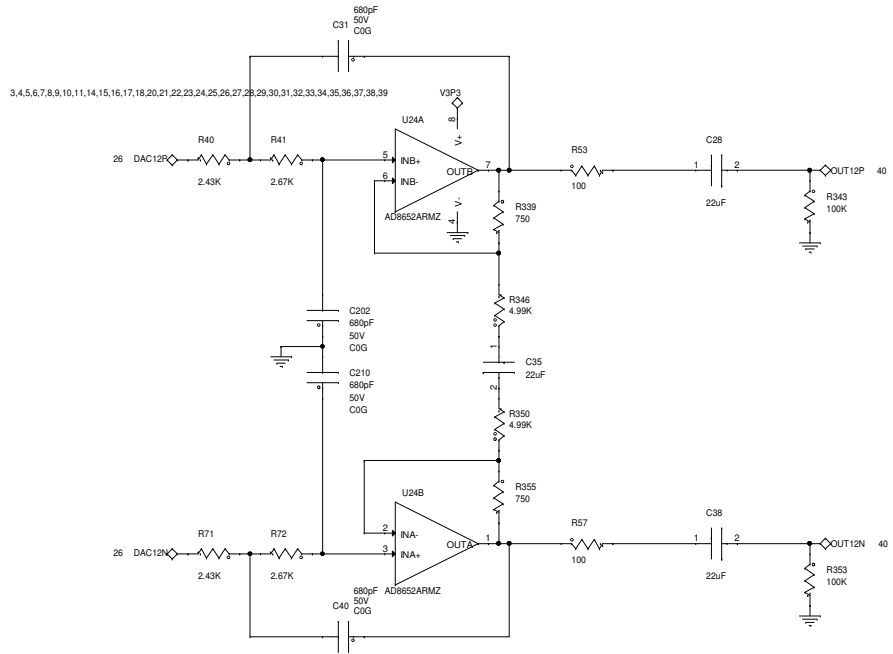
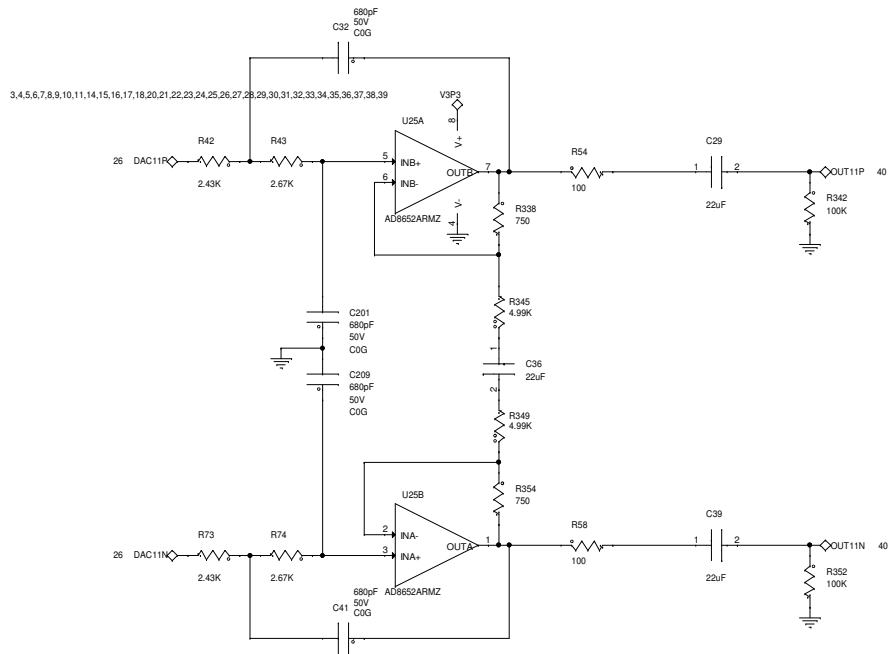

| | | |
|---------------|--|----------------|
| Title | | |
| OUT11 / OUT12 | | |
| Size | Document Number | Rev |
| C | EVAL-MELODY-7 Audio/Video Evaluation Board | 0.2 |
| Date: | Wednesday, January 04, 2017 | Sheet 33 of 40 |

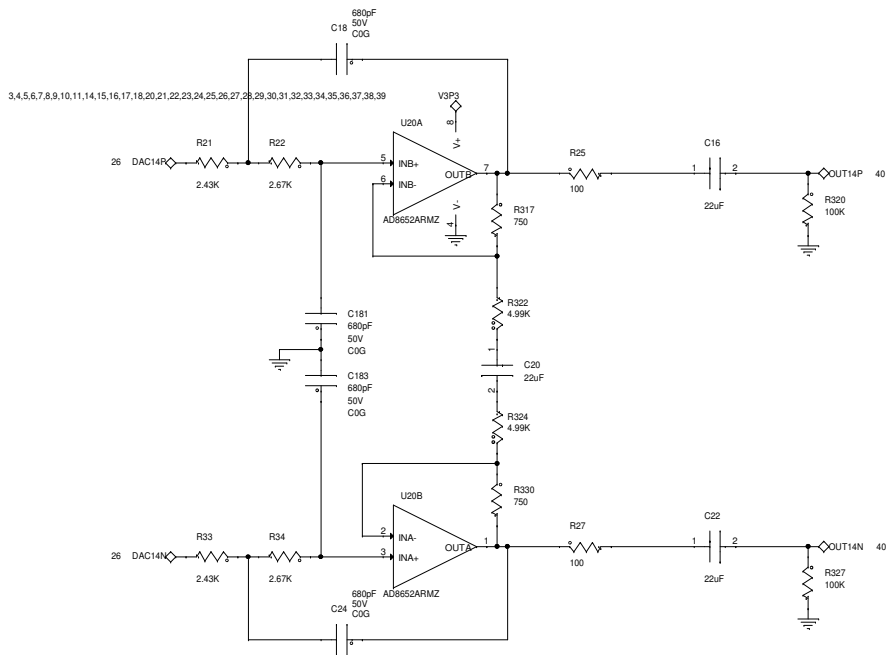
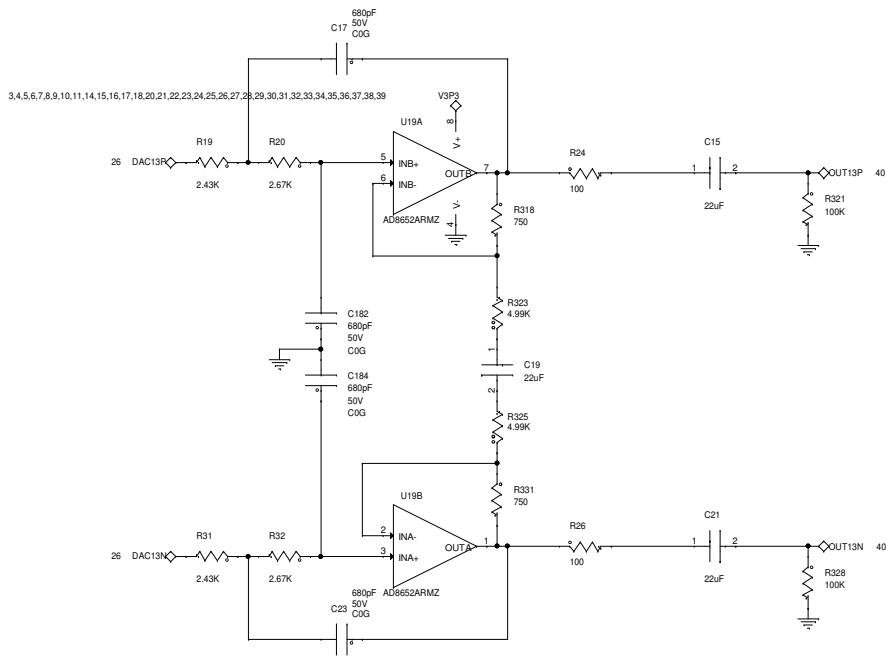

| | | | |
|-------|-----------------------------|--|----------|
| Title | | OUT13 / OUT14 | |
| Size | Document Number | EVAL-MELODY-7 Audio/Video Evaluation Board | |
| C | | Rev | 0.2 |
| Date: | Wednesday, January 04, 2017 | Sheet | 34 of 40 |

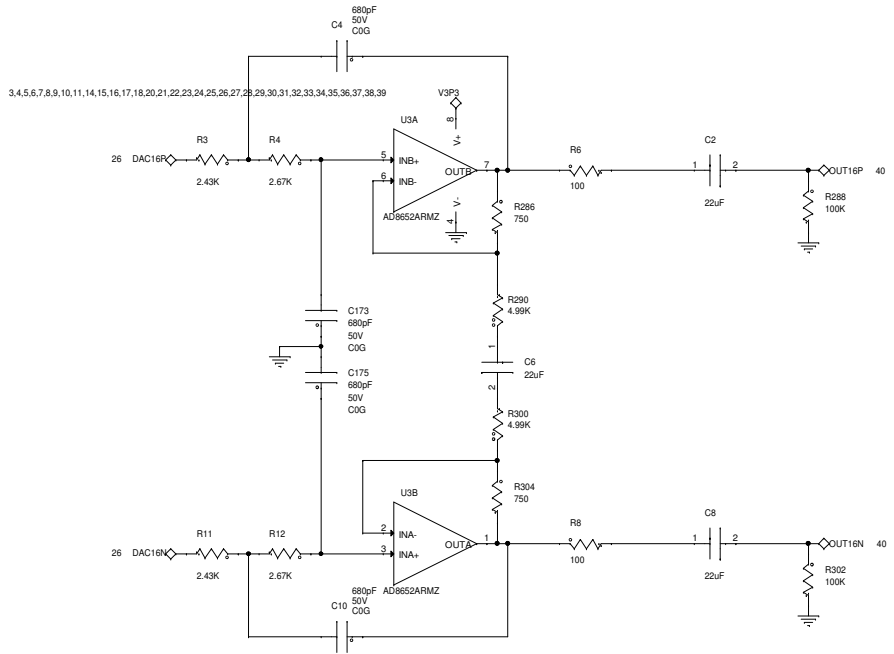
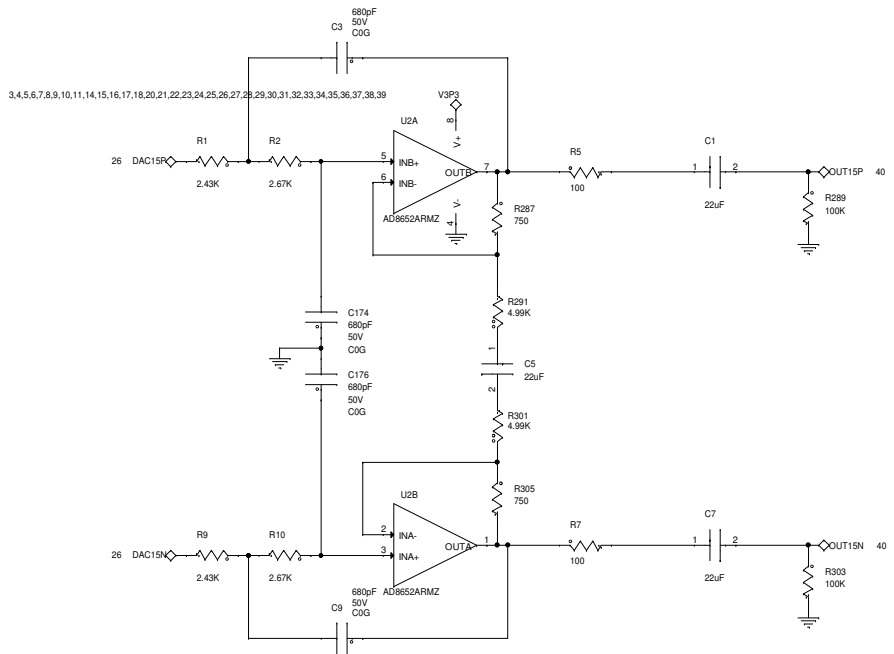

| | | |
|---------------|--|----------------|
| Title | | |
| OUT15 / OUT16 | | |
| Size | Document Number | Rev |
| C | EVAL-MELODY-7 Audio/Video Evaluation Board | 0.2 |
| Date: | Wednesday, January 04, 2017 | Sheet 35 of 40 |

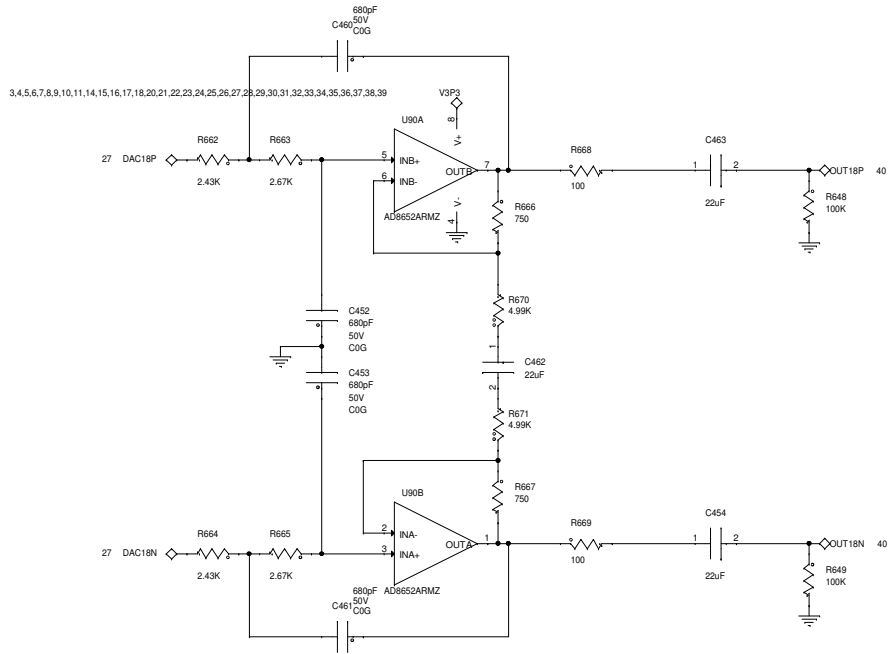
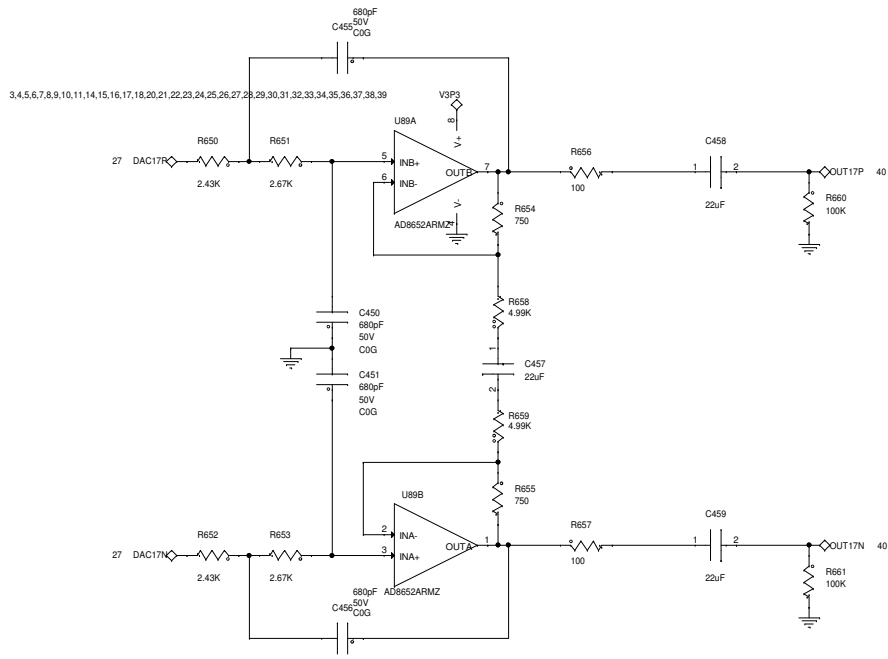

| | | |
|---------------|--|----------------|
| Title | | |
| OUT17 / OUT18 | | |
| Size | Document Number | Rev |
| C | EVAL-MELODY-7 Audio/Video Evaluation Board | 0.2 |
| Date: | Wednesday, January 04, 2017 | Sheet 36 of 40 |

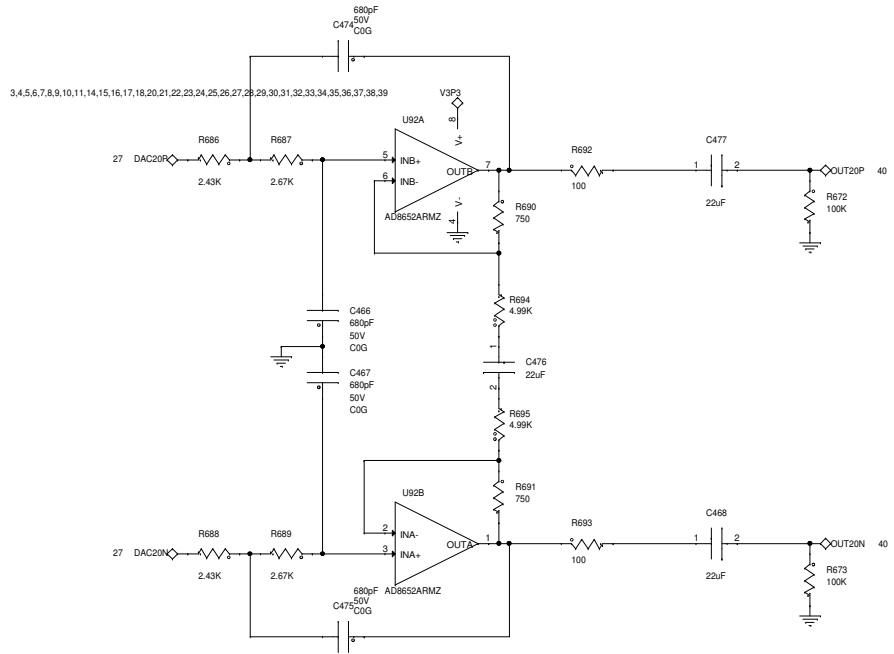
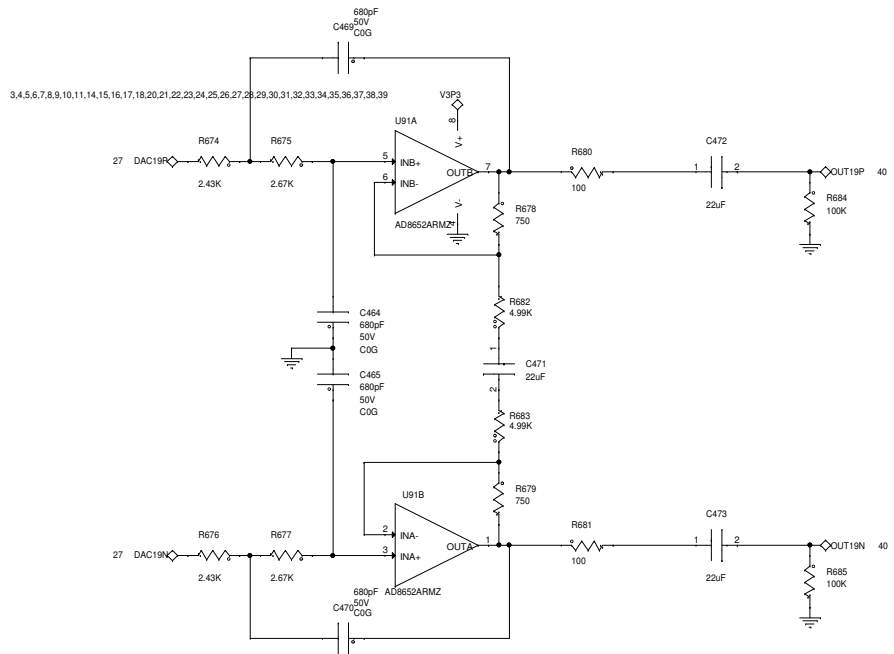

| | | |
|---------------|--|----------------|
| Title | | |
| OUT19 / OUT20 | | |
| Size | Document Number | Rev |
| C | EVAL-MELODY-7 Audio/Video Evaluation Board | 0.2 |
| Date: | Wednesday, January 04, 2017 | Sheet 37 of 40 |

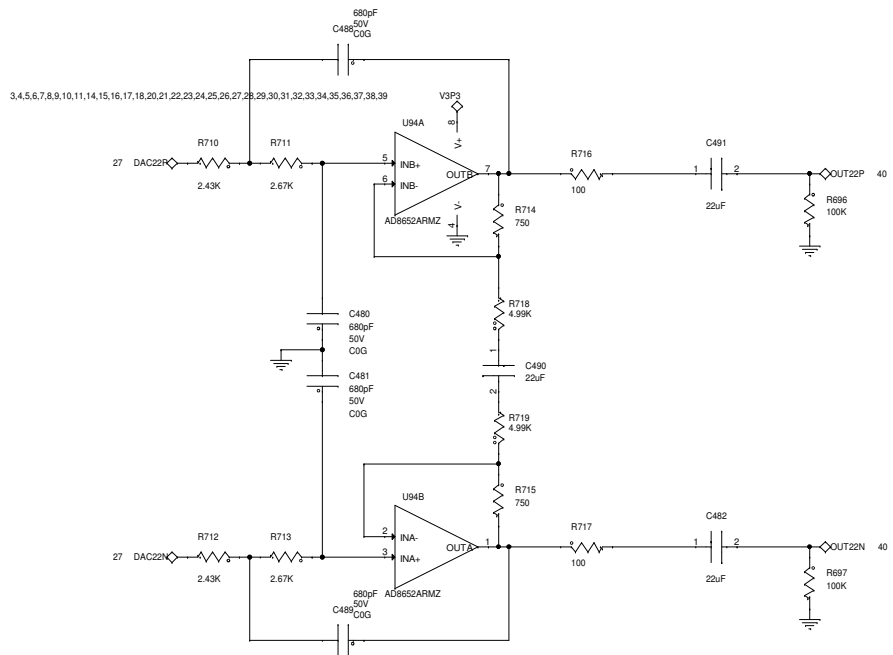
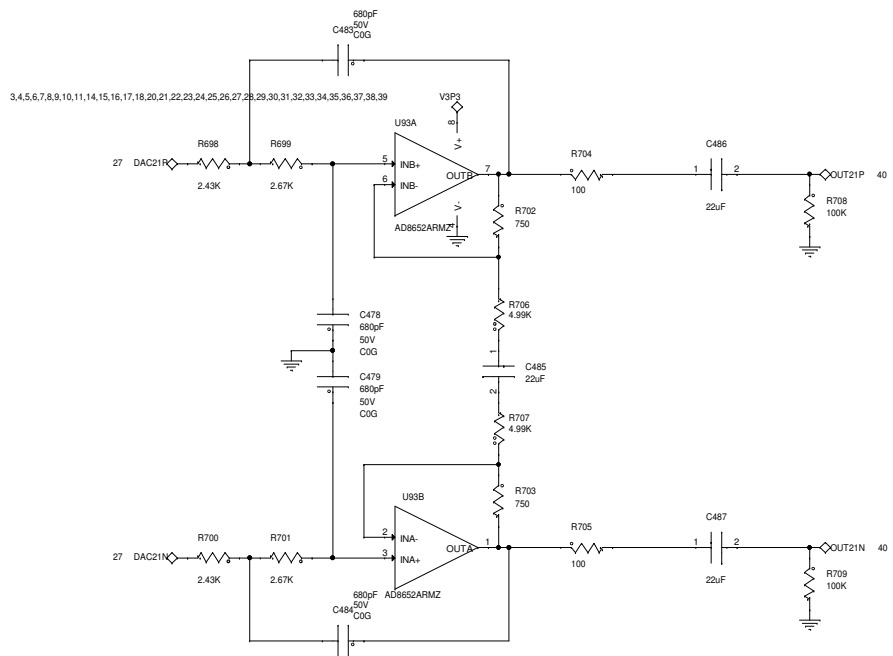

| | | |
|---------------|--|----------------|
| Title | | |
| OUT21 / OUT22 | | |
| Size | Document Number | Rev |
| C | EVAL-MELODY-7 Audio/Video Evaluation Board | 0.2 |
| Date: | Wednesday, January 04, 2017 | Sheet 38 of 40 |

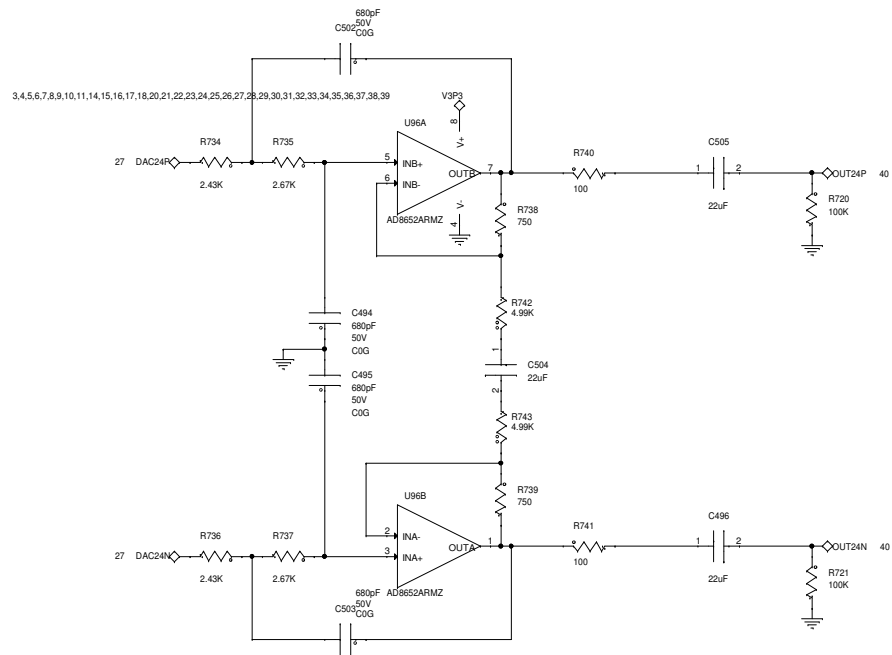
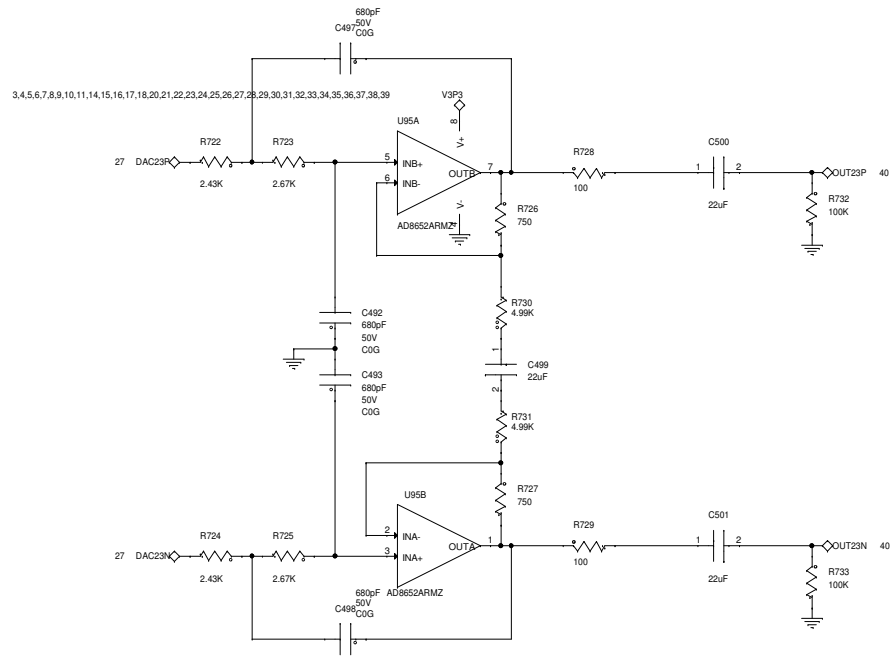

| | | |
|---------------|--|----------------|
| Title | | |
| OUT23 / OUT24 | | |
| Size | Document Number | Rev |
| C | EVAL-MELODY-7 Audio/Video Evaluation Board | 0.2 |
| Date: | Wednesday, January 04, 2017 | Sheet 39 of 40 |

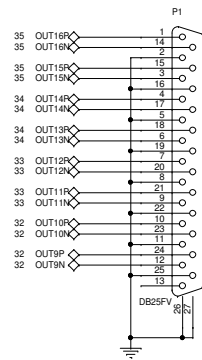
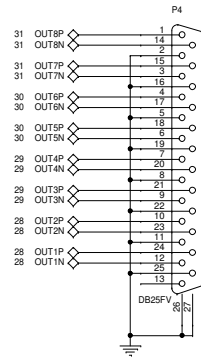
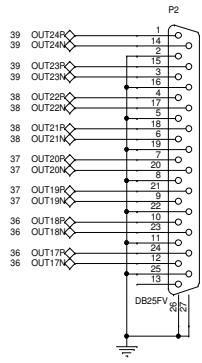

| | | |
|-----------------|--|----------------|
| Title | | |
| DB25 CONNECTORS | | |
| Size | Document Number | Rev |
| C | EVAL-MELODY-7 Audio/Video Evaluation Board | 0.2 |
| Date: | Wednesday, January 04, 2017 | Sheet 40 of 40 |